

AX 345, AX 347, AX 348

Process Indicators with Two Analogue Inputs and Calculations



AX 345	Process Indicator, Display only
AX 346:	Process Indicator with Analogue Outputs 0 - 10 V und 0/4 – 20 mA (see separate manual)
AX 347:	Process Indicator with 2 Presets and Optocoupler Outputs
AX 348:	Process Indicator with Serial RS232 / RS485 Interface

- Two analogue inputs with independent scaling, each +/- 10V or 0/4 – 20 mA
- Operating modes for display of input A or input B or the combinations A + B, A - B, A x B and A : B
- Useful supplementary functions like Tare function, programmable averaging functions, programmable linearization etc.
- Power supply 115/230 VAC and 17-30 VDC in the same unit
- Aux. output 24 V DC / 100 mA for sensor supply

Operating Instructions



Safety Instructions

- This manual is an essential part of the unit and contains important hints about function, correct handling and commissioning. Non-observance can result in damage to the unit or the machine or even in injury to persons using the equipment!
- The unit must only be installed, connected and activated by a qualified electrician
- It is a must to observe all general and also all country-specific and application-specific safety standards
- When this unit is used with applications where failure or mal-operation could cause damage to a machine or hazard to the operating staff, it is indispensable to meet effective precautions in order to avoid such consequences
- Regarding installation, wiring, environmental conditions, screening of cables and earthing, you must follow the general standards of industrial automation industry
- - Errors and omissions excepted –

Version:	Description:
AX34507a_hk/kk/04/2007	First edition
AX34507b_hk/kk/10/2007	CMD key commands added
AX34509a_kk/hk/08/2010	Over-/underflow control added AX347: programmable output assignment, AX38: new model

Table of Contents

1.	Introduction	4
2.	Terminal Assignments	5
2.1.	Power supply	6
2.2.	Aux. voltage output	6
2.3.	Analogue measuring inputs	6
2.4.	Optocoupler transistor outputs (model AX 347 only).....	7
2.5.	Serial RS232 / RS485 interface (AX 348 only).....	8
3.	Jumper settings.....	9
4.	How to Operate the Keys	11
4.1.	Normal display state	11
4.2.	Parameter settings	12
4.2.1.	How to select a parameter	12
4.2.2.	How to change parameter settings	12
4.2.3.	How to store settings	12
4.2.4.	Time-out function.....	12
4.3.	Teach operation.....	13
4.4.	Set all parameters to "Default"	13
4.5.	Code Locking of the Keypad.....	13
5.	The Parameter Menu	14
6.	Setting of Parameters.....	16
6.1.	Basic Parameters.....	16
6.2.	Operational parameters.....	17
6.3.	Modes of operation	18
6.3.1.	Single mode (input A only).....	18
6.3.2.	Dual Mode (Inputs A and B separately).....	19
6.3.3.	Combined Modes [A + B], [A - B], [A : B], [A x B]	20
6.4.	Additional settings for the Preselections (model AX 347 only).....	21
6.4.1.	Basic settings for the Presets:	21
6.4.2.	Characteristics of the switching hysteresis.....	22
6.4.3.	Operational settings for presets:	23
6.4.4.	Actual switching state of the outputs:	23
6.4.5.	Response time of switching outputs	24
6.5.	Additional Parameters for the Serial Interface (model AX 348 only).....	25
6.5.1.	Communication settings in the Basic Menu:.....	25
6.5.2.	Operational Parameters for configuration of the interface:	26
6.5.3.	PC-Mode	27
6.5.4.	Printer Mode	28
7.	Commissioning	29
8.	Special Functions.....	30
8.1.	Tare / Offset function	30
8.2.	Linearization	30
8.3.	Manual input or „Teaching“ of the interpolation points	32
8.4.	Overflow and Underflow Control	34
9.	Technical Specifications.....	35
9.1.	Dimensions	35
9.2.	Technical data	36
9.3.	Commissioning Form	37

1. Introduction

Some of the general demands to an up-to-date process controller for automation industry are always high flexibility, combined with easy and simple operability.

Many applications require two separate analogue inputs for use with single or combined operation.

Also it may be important to display and evaluate both, linear and non-linear analogue inputs at an acceptable accuracy, which requires programmable linearization functions.

Process controllers of series AX 345 - 348 have been designed for this kind of requirements.

Model **AX 345** provides display function only.

Model **AX 346** provides additional analogue outputs +/-10 volts and 0/4 - 20 mA
(a separate manual is available for the AX346 model)

Model **AX347** provides two additional Preselections with Optocoupler outputs

Model **AX 348** provides additional serial communication via RS232 / RS485 interface

All other functions within this controller family are fully similar.



The present operating instructions are valid for models AX 345, AX347 and AX 348 only.
Separate operating instructions are available for model AX 346

2. Terminal Assignments

AX 345: Basic model

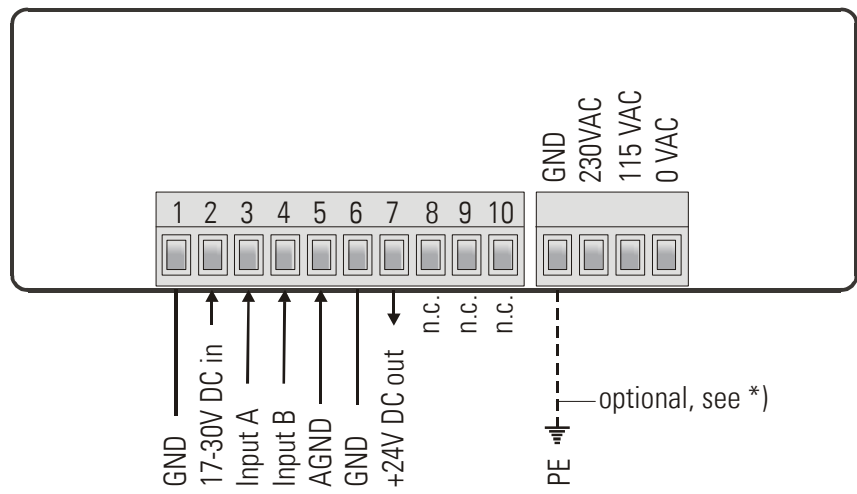

AX 347: Model with two presets and optocoupler outputs

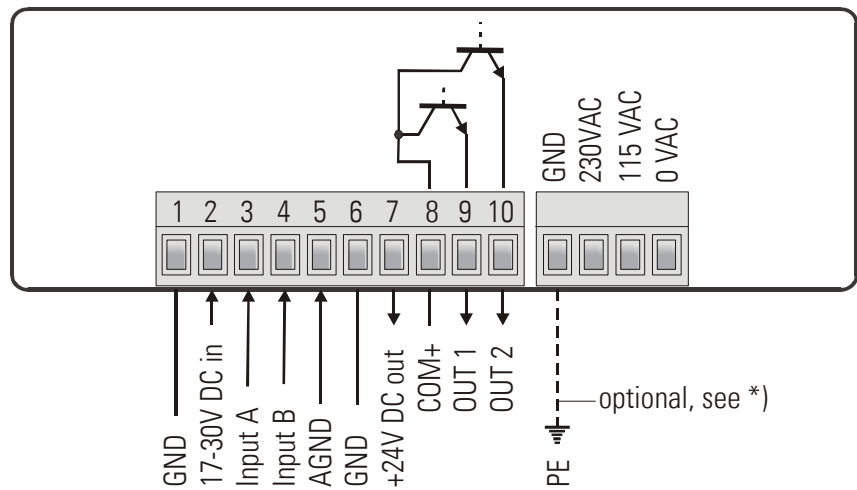

AX 348: Model with serial RS232 / RS485 interface

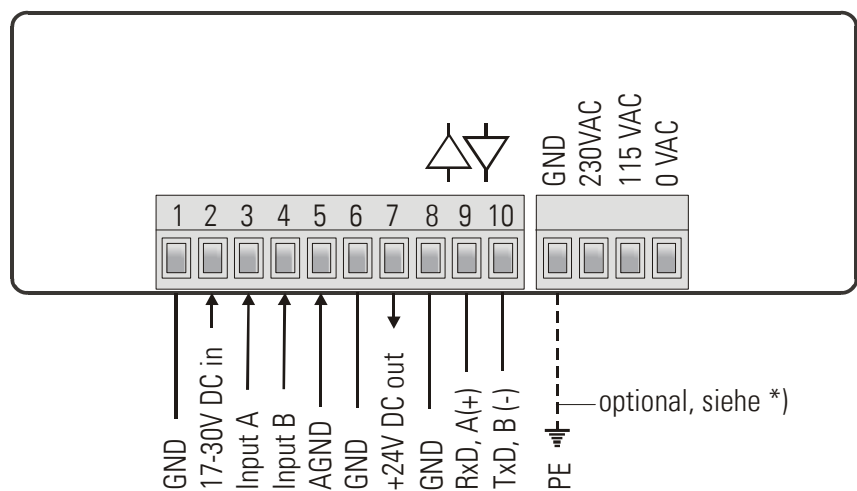

*) The connection of PE is optional and not necessary for safety or for EMC.
However, with some applications, it can be useful to ground the common potential of all signal lines



- When using the earthing option, please be aware that all terminals marked GND or AGND will be earthed.
- Multiple earthing on different positions of an installation may cause problems, especially with poor overall performance of the whole earthing and screening system!
- The minus potential of analogue inputs is internally connected to the minus of the DC supply. When you like to use current loops through several units, it is therefore necessary to supply the units from either AC power or from several, potential-separated DC sources.

2.1. Power supply

The unit accepts DC supply from 17 to 30 VDC with use of terminals 1 and 2. The consumption depends on the level of the supply voltage (typical 80 mA at 30V or 130mA at 17V, plus current taken from the aux. output).

For AC supply, terminals 0 VAC and 115 VAC or 230 VAC can be used. The total AC power is approximately 7.5 VA.

2.2. Aux. voltage output

Terminal 7 provides an auxiliary output of 24 V DC / 100 mA max. for supply of sensors and encoders. This is valid for AC supply and DC supply of the unit as well.

2.3. Analogue measuring inputs

There are two analogue inputs with common minus potential available (Input A and Input B). Both refer to the AGND potential of terminal 5 which is internally connected to terminals 1, 6 and GND.

The analogue inputs can be configured for voltage input (+/- 10 V) or current input (0 / 4 – 20 mA) by means of internal jumpers.



Ex factory, both inputs are always configured for current input.
(see section 3 for jumper settings)

2.4. Optocoupler transistor outputs (model AX 347 only)

The outputs provide programmable switching characteristics and are potential-free. Please connect terminal 8 (COM+) to the positive potential of the voltage you like to switch (range 5V...35V).

You must not exceed the maximum output current of 150mA. Where you intend to switch inductive loads, please provide filtering of the coil by means of external diodes.

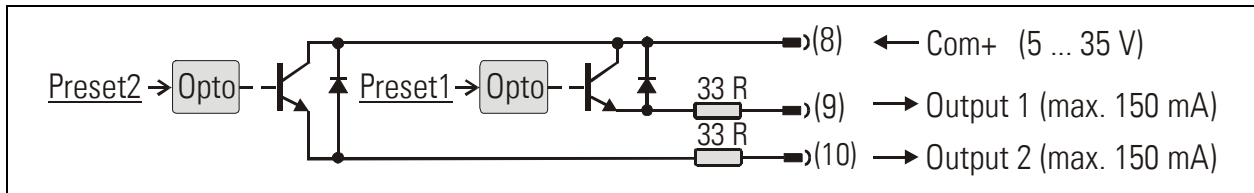

2.5. Serial RS232 / RS485 interface (AX 348 only)

Ex factory the unit is set to RS232 communication. This setting can be changed to RS485 (2-wire) by means of an internal DIL switch. To access the DIL switch, you must remove the screw terminal connectors and the backplane. Then pull the board to the rear to remove the PCB from the housing.

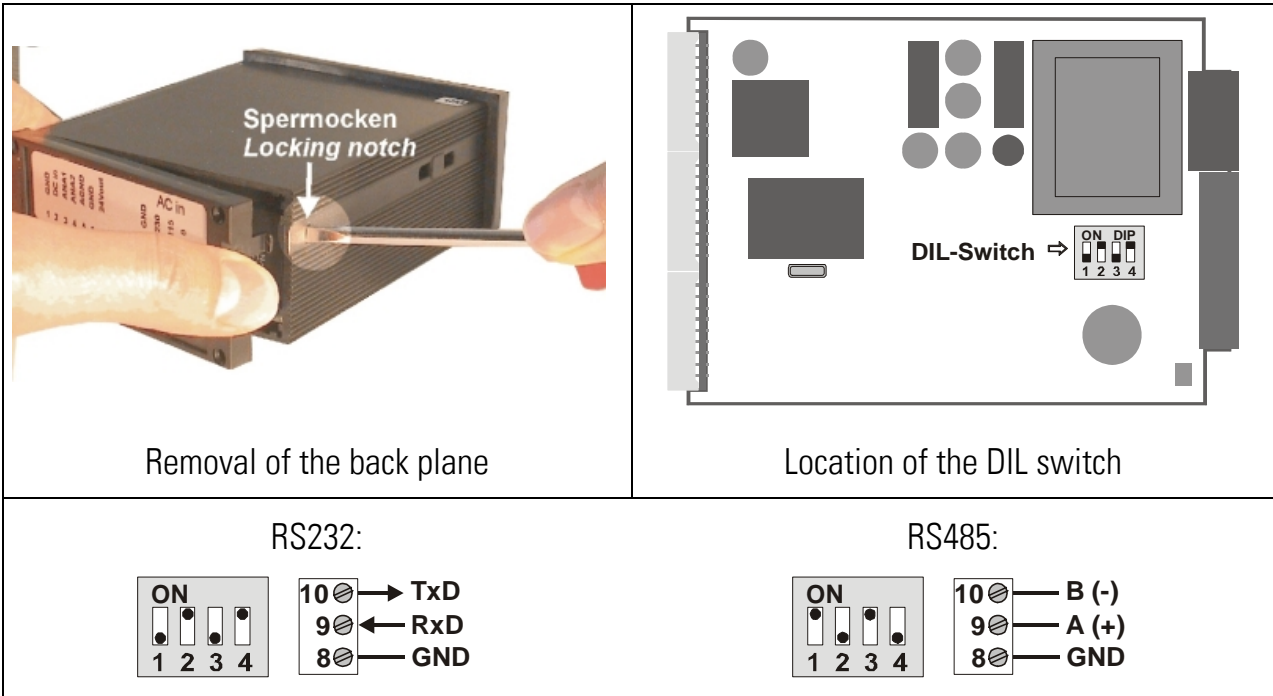

- Never set DIL switch positions 1 and 2 or DIL switch positions 3 and 4 to "ON" at the same time!
- After setting the switch, shift the print carefully back to the housing and avoid damage of the front pins for connection to the front keypad plate.

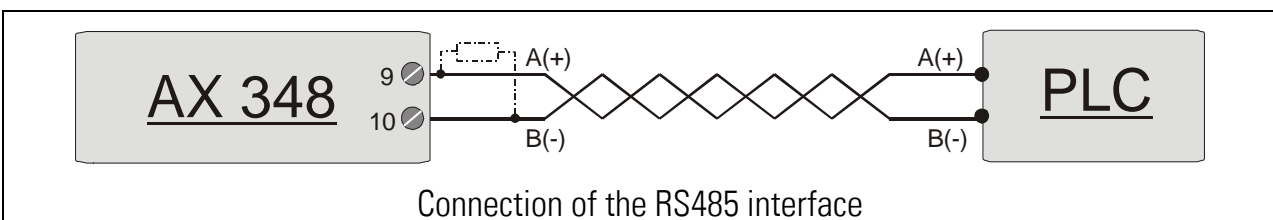
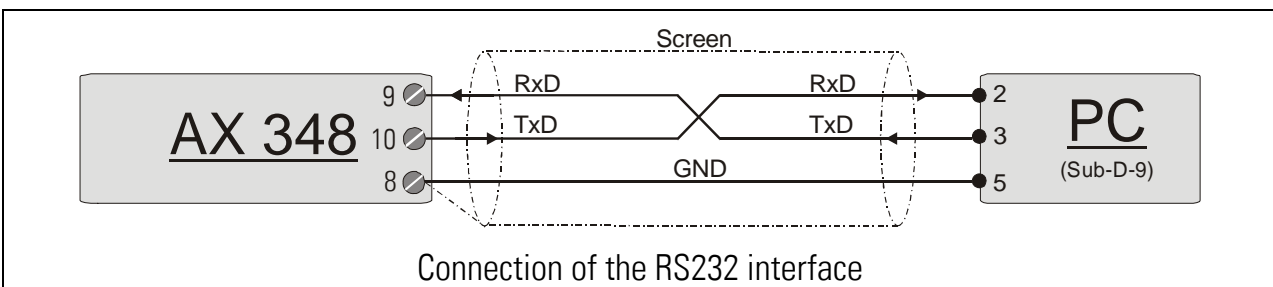

3. Jumper settings

When your input signal is a current of 0-20 mA or 4-20 mA, there is no need to change jumper settings and you can skip this section.

Where however you intend to use one or both inputs for voltage signals, you must change the internal jumper settings correspondingly.

To access the jumpers, you have to disconnect the rear screw terminal strips, remove the back plane from the unit and pull the PCB out of the housing

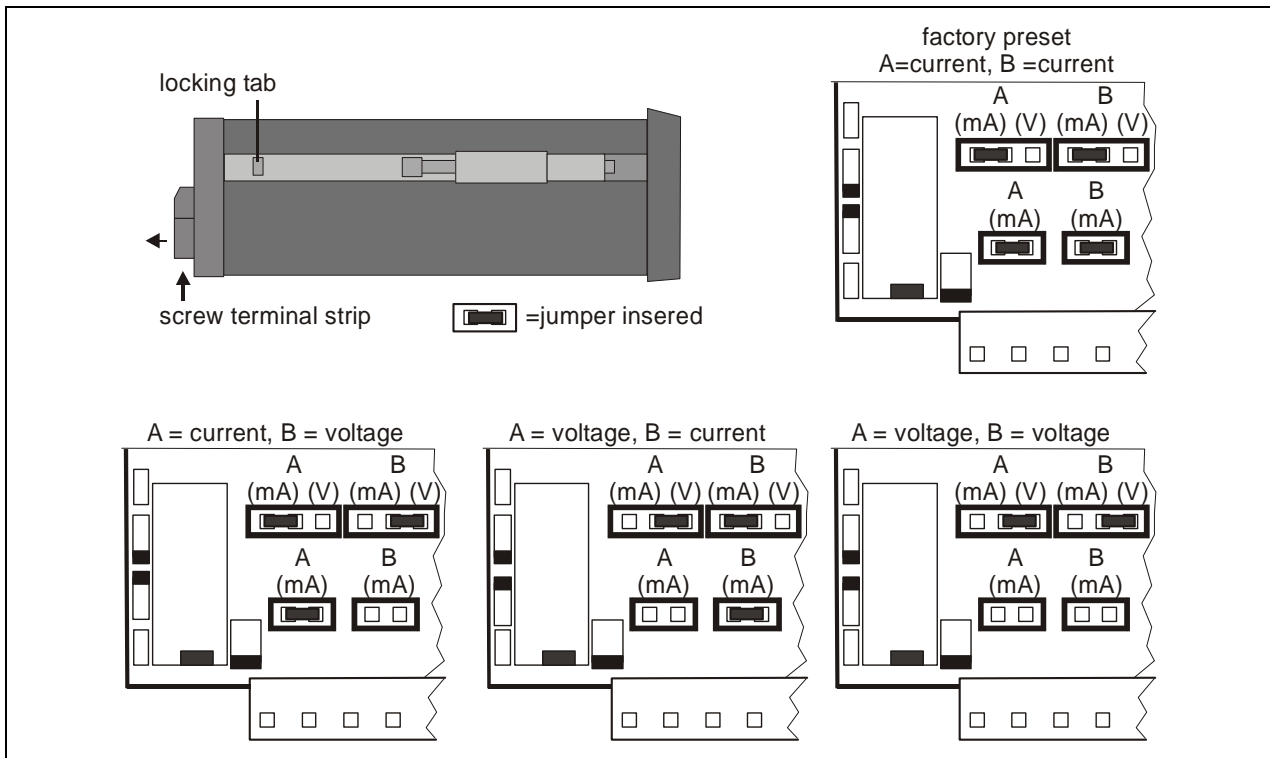

Wrong jumper settings may cause serious damage to the unit!

After setting the jumpers, please shift the print carefully back to the housing, in order not to damage the front pins for connection to the keypad plate.



Current inputs are automatically scaled to an input range of 0/4 – 20 mA.
Voltage inputs use the standard range of +/- 10V.

You are free to measure voltages up to 120 volts DC by use of a remote resistance in series to the input line (please observe applicable safety standards!). You can calculate the value from the formula

$$R_x [k\Omega] = 3 \times V_x [V] - 30$$

R = resistance value
V = input voltage

Example: Desired input = 100 volts:
 $R = [3 \times 100] - 30 (k\Omega) = 270 k\Omega$

With regard to the scaling procedure described later, the new maximum input with resistance will work like a 10 volts signal with no resistance

4. How to Operate the Keys

The unit uses 3 front keys for all setup operations. Subsequently, the key functions will be named as shown in the table below.

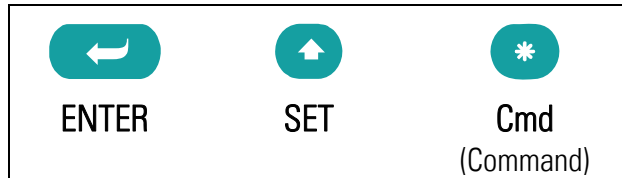

The functions of the keys are depending on the actual operating state of the unit.

The following three operating states apply:

- **Normal display state**
- **Setup state**
 - a.) Basic setup
 - b.) Operational parameter setup
- **Teach operation**

4.1. Normal display state



You can change over to the other states while the unit is in the normal display state only.

Change over to	Key operation
Basic setup	Keep ENTER and SET down simultaneously for 3 seconds
Operational parameter setup	Keep ENTER down for 3 seconds.
Teach operation	Keep SET down for 3 seconds

The Cmd key is only used for execution of the Tare function, the Reset function and for Teaching the interpolation points for linearization (see section 8).

4.2. Parameter settings

4.2.1. How to select a parameter

The ENTER key will scroll through the menu. The SET key allows to select the corresponding item and to change the setting or the numeric value. After this, the selection can be stored by ENTER again, which automatically changes over to the next menu item.

4.2.2. How to change parameter settings

With numerical entries, at first the lowest digit will blink. When keeping the SET key down, the highlighted digit will scroll in a continuous loop from 0 ... 9 ... 0 ... 9. When you release the SET key, the actual digit will remain and the next digit will be highlighted (blink).

This procedure allows setting all digits to the desired values. After the most significant digit has been set, the low order digit will blink again and you can do corrections if necessary.

With signed parameters, the high order digit will only scroll between the values "0" (positive) and "-" (negative)

4.2.3. How to store settings

To store the actual setting, press the ENTER key, which will also automatically scroll forward the menu.

The unit changes from programming mode to normal operation when you keep down the ENTER key again for at least 3 seconds.

4.2.4. Time-out function

The "time-out" function will automatically conclude every menu level, when for a break period of 10 seconds no key has been touched. In this case, any entry which has not been confirmed by ENTER yet would remain unconsidered.

4.3. Teach operation



The Time-out function will be switched off during all Teach operations

Key	Function
	ENTER will conclude or abort any Teach operation in progress
	SET function is fully similar to normal set-up operation
	Cmd will store the display value to the register and will change over to the next interpolation point.

For details of the Teach procedure see section 8.3.

4.4. Set all parameters to “Default”

At any time you can return all settings to the factory default values.

The factory default settings are shown in the parameter listings in section 6.



When you decide to set all parameters to „default“, please be aware that all previous settings will be lost and you will need to do the whole set-up procedure once more

To execute the „Default“ setting function:

- Power the unit down.
- Press the ENTER key.
- Power the unit up again while the ENTER key is kept down

4.5. Code Locking of the Keypad

When the code locking of the keypad has been switched on, any key access first results in display of



To access the menu you must press the key sequence



within 10 seconds, otherwise the unit will automatically return to the normal display mode.

5. The Parameter Menu

The menu provides one section with "basic parameters" and another section with "operational parameters". On the display you will only find those parameters which have been enabled by the basic settings. E.g. when the Linearization Functions have been disabled in the basic set-up, the associated linearization parameters will also not appear in the parameter menu.

All parameters, as good as possible, are designated by text fragments. Even though the possibilities of forming texts are very limited with a 7-segment display, this method has proved to be most suitable for simplification of the programming procedure.

The subsequent table is to show the general structure of the whole menu only. Detailed descriptions of all parameters will follow in section 6.

Menu overview:

	<u>Basic Parameters</u>	
AX 345	AX 347	AX 348
„n)odE“	„n)odE“	„n)odE“
„briGht“	„briGht“	„briGht“
"UPdAt"	"UPdAt"	"UPdAt"
„CodE „	„CodE „	„CodE „
„LinEAR“	„LinEAR“	„LinEAR“
"Crnd"	"Crnd"	"Crnd"
	„Src 1 "	"S-Unit"
	„CHAR 1"	"S-Forn"
	„Src 2 "	"S-bAUd"
	„CHAR 2"	
	„HYSt 1"	
	„HYSt 2"	

Operational Parameters		
Single Mode	Dual Mode	Combined Modes
	„PrES 1" (AX 347 only)	
	„PrES 2" (AX 347 only)	
„inPutA"	„inPutA"	„inPutA"
„StArtA"	„StArtA"	„StArtA"
„End A"	„End A"	„End A"
„dPoi A"	„dPoi A"	„dPoi A"
„FiLt A"	„FiLt A"	„FiLt A"
"OFFS A" *)	"OFFS A" *)	
	„inPutb"	„inPutb"
	„StArtb"	„StArtb"
	„End b"	„End b"
	„dPoi b"	„dPoi b"
	„FiLt b"	„FiLt b"
	OFFS b" *)	
		„n) FAc"
	„d FAc"	
	„P FAc"	
	„dPoint"	
	"S-tim" (AX 348 only)	
	"S-mod" (AX 348 only)	
	"S-CodE" (AX 348 only)	
	"P01_H " **)	
	"P01_Y " **)	
	---->	
	"P16_H " **)	
	"P16_Y " **)	

*) appears only when the Offset function has been enabled

**) appears only when the linearization is switched on

6. Setting of Parameters

6.1. Basic Parameters

In general, the parameters described subsequently must be set with the very first commissioning of the unit only. For best comprehensibility, this section describes setup of all display functions only as needed for model AX 345, and settings applicable to preselections and switching outputs of AX 347 are described separately.

Menu Text		Default
Mode of operation	<div style="border: 1px solid black; padding: 2px; display: inline-block;">Mode of operation</div> <div style="display: flex; flex-direction: column; gap: 5px;"> <div style="display: flex; align-items: center;"> <div style="border: 1px solid black; padding: 2px; margin-right: 5px;">S i n G L E</div> <div>Single input operation (input A only)</div> </div> <div style="display: flex; align-items: center;"> <div style="border: 1px solid black; padding: 2px; margin-right: 5px;">d u A L</div> <div>Dual input operation (input A and input B separately)</div> </div> <div style="display: flex; align-items: center;"> <div style="border: 1px solid black; padding: 2px; margin-right: 5px;">A + b</div> <div>Sum operation (input A + input B)</div> </div> <div style="display: flex; align-items: center;"> <div style="border: 1px solid black; padding: 2px; margin-right: 5px;">A - b</div> <div>Differential operation (input A – input B)</div> </div> <div style="display: flex; align-items: center;"> <div style="border: 1px solid black; padding: 2px; margin-right: 5px;">A ÷ b</div> <div>Dividing operation (ratio A : B)</div> </div> <div style="display: flex; align-items: center;"> <div style="border: 1px solid black; padding: 2px; margin-right: 5px;">A × b</div> <div>Multiplying operation (product A x B)</div> </div> </div>	<div style="border: 1px solid black; padding: 2px; display: inline-block;">S i n G L E</div>
Brightness of the display	<div style="border: 1px solid black; padding: 2px; display: inline-block;">Brightness of the display</div> <div style="display: flex; flex-direction: column; gap: 5px;"> <div style="display: flex; align-items: center;"> <div style="margin-right: 5px;">„ 100“</div> <div>100% of maximum brightness</div> </div> <div style="display: flex; align-items: center;"> <div style="margin-right: 5px;">„ 80“</div> <div>80% of maximum brightness</div> </div> <div style="display: flex; align-items: center;"> <div style="margin-right: 5px;">„ 60“</div> <div>60% of maximum brightness</div> </div> <div style="display: flex; align-items: center;"> <div style="margin-right: 5px;">„ 40“</div> <div>60% of maximum brightness</div> </div> <div style="display: flex; align-items: center;"> <div style="margin-right: 5px;">„ 20“</div> <div>20% of maximum brightness</div> </div> </div>	„100“
Update time of the display	<div style="border: 1px solid black; padding: 2px; display: inline-block;">Update time of the display</div> Updates the display every x.xxx seconds. Setting range from 0.050 to 5.999 seconds.	„0.300“
Keypad interlock code	<div style="border: 1px solid black; padding: 2px; display: inline-block;">Keypad interlock code</div> <div style="display: flex; flex-direction: column; gap: 5px;"> <div style="display: flex; align-items: center;"> <div style="border: 1px solid black; padding: 2px; margin-right: 5px;">no</div> <div>Keypad enabled continuously</div> </div> <div style="display: flex; align-items: center;"> <div style="border: 1px solid black; padding: 2px; margin-right: 5px;">ALL</div> <div>Keypad locked for any access</div> </div> <div style="display: flex; align-items: center;"> <div style="border: 1px solid black; padding: 2px; margin-right: 5px;">P_FrEE</div> <div>Keypad locked, except for access to preselections Pres 1 und Pres 2</div> </div> </div>	<div style="border: 1px solid black; padding: 2px; display: inline-block;">no</div>
Mode of linearization	<div style="border: 1px solid black; padding: 2px; display: inline-block;">Mode of linearization</div> <div style="display: flex; flex-direction: column; gap: 5px;"> <div style="display: flex; align-items: center;"> <div style="border: 1px solid black; padding: 2px; margin-right: 5px;">no</div> <div>No linearization. The corresponding parameters will not appear in the menu.</div> </div> <div style="display: flex; align-items: center;"> <div style="border: 1px solid black; padding: 2px; margin-right: 5px;">1-9UR</div> <div>Linearization for the numeric range 0 – 99999. Interpolation points to be set in the positive range only (negative values will appear as a mirror).</div> </div> <div style="display: flex; align-items: center;"> <div style="border: 1px solid black; padding: 2px; margin-right: 5px;">4-9UR</div> <div>Linearization over the full range –99999 to +99999</div> </div> </div>	<div style="border: 1px solid black; padding: 2px; display: inline-block;">no</div>

Menu Text		Default
Crnd	Command key enable	off
	<input data-bbox="359 336 518 392" type="checkbox"/> off The Command key is switched off and no Offset values will appear in the menu	
	<input data-bbox="359 425 518 481" type="checkbox"/> offset The Cmd key will execute the Tare/Offset function	
	<input data-bbox="359 492 518 548" type="checkbox"/> teach The Cmd key will execute the Teach function	
	<input data-bbox="359 560 518 616" type="checkbox"/> both The Cmd key will execute both, the Tare and the Teach function	

6.2. Operational parameters

After the basic setup, you can access the operational parameters by pressing ENTER for at least 3 seconds. You will only find those parameter texts that are relevant for your mode of operation.

To exit the menu, keep again ENTER down for at least 3 seconds, or just wait for the automatic Time-Out function.

6.3. Modes of operation

6.3.1. Single mode (input A only)

Menu Text	Setting Range	Default
Input A <u>Input A range</u> Set the desired range for input A <input type="checkbox"/> in U Voltage +/-10V <input checked="" type="checkbox"/> in .0 Current 0-20 mA <input type="checkbox"/> in .4 Current 4-20 mA		<input type="checkbox"/> in .0
Start A <u>Start value A</u> Value which the unit will display with a zero input signal of 0 volts or 0/4 mA	-99999 ... 99999	0
End A <u>End value A</u> Value which the unit will display with a full scale input of 10 volts or 20 mA	-99999 ... 99999	1000
dPo. A <u>Decimal point for signal A</u> Select the desired position of the decimal point 000000 No decimal point 00000.0 one decimal position ----> 0.00000 five decimal positions		00000.0
Filter A <u>Average filter input A</u> Adjustable floating average filter for smoothing the display with unsteady input signals <input type="checkbox"/> oFF No filtering 2,4,8,16 Number of floating averaging cycles		<input type="checkbox"/> oFF
OFFSA <u>Offset value for input A *)</u> Offset value for the zero displacement of input A signals	-99999 ... 99999	0
*) When the Tare function is switched on only		

6.3.2. Dual Mode (Inputs A and B separately)



With this mode, the SET key selects between display of channel A and display of channel B, and the bar of the high order LED indicates which of the two channels is actually in display.

Menu Text		Input Range	Default
Input b	<p>Input B range Set the desired range for input B</p> <p>in U Voltage +/-10V</p> <p>in .0 Current 0-20 mA</p> <p>in .4 Current 4-20 mA</p>		in .0
Start b	<p>Start value B Value which the unit will display with a zero input signal of 0 volts or 0/4 mA</p>	-99999 ... 99999	0
End b	<p>End value B Value which the unit will display with a full scale input of 10 volts or 20 mA</p>	-99999 ... 99999	1000
dPo. b	<p>Decimal point for signal B Select the desired position of the decimal point</p> <p>000000 No decimal point</p> <p>00000.0 one decimal position</p> <p>----></p> <p>0.00000 five decimal positions</p>		000000
Flt b	<p>Average filter input B Adjustable floating average filter for smoothing the display with unsteady input signals</p> <p>off No filtering</p> <p>2,4,8,16 Number of floating averaging cycles</p>		off
OFFS b	<p>Offset value for input B *) Offset value for the zero displacement of input A signals</p>	-99999 ... 99999	0

*) When Tare function is switched on only

6.3.3. Combined Modes [A + B], [A - B], [A : B], [A x B]

These modes allow displaying either the single channels A and B or the calculated result according to the selected combination. The SET key allows scrolling between the three displays.

A →  The upper bar of the high order digit indicates that you display channel A.

B →  The lower bar of the high order digit indicates channel B.

<AB>  When no bar is lit, the display shows the result of the calculation, according to the combination set.

When you use one of the combined modes, you will first have to do the same settings as with the “Dual” mode for individual display of inputs A and B.

The combined display will then be the result calculated from both single values.

The following additional parameters provide a final scaling facility, so you can read out the result of your combination in proper engineering units:

Menu Text	Setting Range	Default
nn FAc <u>Proportional Scaling Factor</u> Multiplies the result by this setting	-10000 ... 10000	1000
d FAc <u>Reciprocal Factor</u> Divides the result by this setting	1 ... 99999	1000
P FAc <u>Additive Constant</u> Adds or subtracts this setting	-99999 ... 99999	0
dPo, nt <u>Decimal Point</u> Sets the decimal point for the combined display value 000000 No decimal point 00000.0 one decimal position ----> 0.00000 five decimal positions		000000

Calculation Formula:

$$\text{Final display value} = \text{value calculated from } \langle \text{AB} \rangle \times \frac{\text{m_Fac}}{\text{d_Fac}} \text{ +/- } \text{P_Fac}$$

6.4. Additional settings for the Preselections (model AX 347 only)

6.4.1. Basic settings for the Presets:

The basic setup menu provides the following additional parameters which are relevant for the operation of the presets and outputs only:

Menu Text		Setting Range	Default
Src 1	Signal source of switching output „OUT1“ OUT1 depends on analogue input A OUT1 depends on analogue input B *) OUT1 depends on the combination [A,B] of both analogue inputs **)	In A In b In A_b	In A
CHAR 1	Output 1 switching characteristics _J_ GE Greater/Equal: Output is statically active with display greater or equal Preset. _J_ LE Lower/Equal: Output is statically active with display lower or equal Preset. _n_ GE Greater/Equal: Output is dynamically active with display greater or equal Preset. (timed output impulse) _n_ LE Lower/Equal: Output is dynamically active with display lower or equal Preset. (timed output impulse)		_J_ GE
Src 2	Signal source of switching output „OUT2“ OUT2 depends on analogue input A OUT2 depends on analogue input B *) OUT2 depends on the combination [A,B] of both analogue inputs **)	In A In b In A_b	In A

*) Requires Analogue input B to be activated (i.e. operating mode setting "Dual" or "Combined")

***) Requires operating mode setting "Combined"

Menu Text		Setting Range	Default
CHAR 2	Output 2 switching characteristics		_J_ GE
	J GE See above		
	J LE See above		
	N GE See above		
	N LE See above		
	J 1-2 Output is statically active when the display reaches the value of Preset 1 – Preset 2 *)		
	N 1-2 Output is dynamically active when the display reaches the value of Preset 1 – Preset 2 *)		
HYS1	Switching Hysteresis 1 Programmable Hysteresis for output 1	0 ... 99999	0
HYS2	Switching Hysteresis 2 Programmable Hysteresis for output 2	0 ... 99999	0
*) Serves to generate an anticipation signal at a fixed distance to the preset 1 signal. The anticipation automatically follows the settings of preset 1.			

6.4.2. Characteristics of the switching hysteresis

The direction of operation of the Hysteresis setting depends on the selected switching characteristics „GE“ or „LE“ and is explained in the figure below:

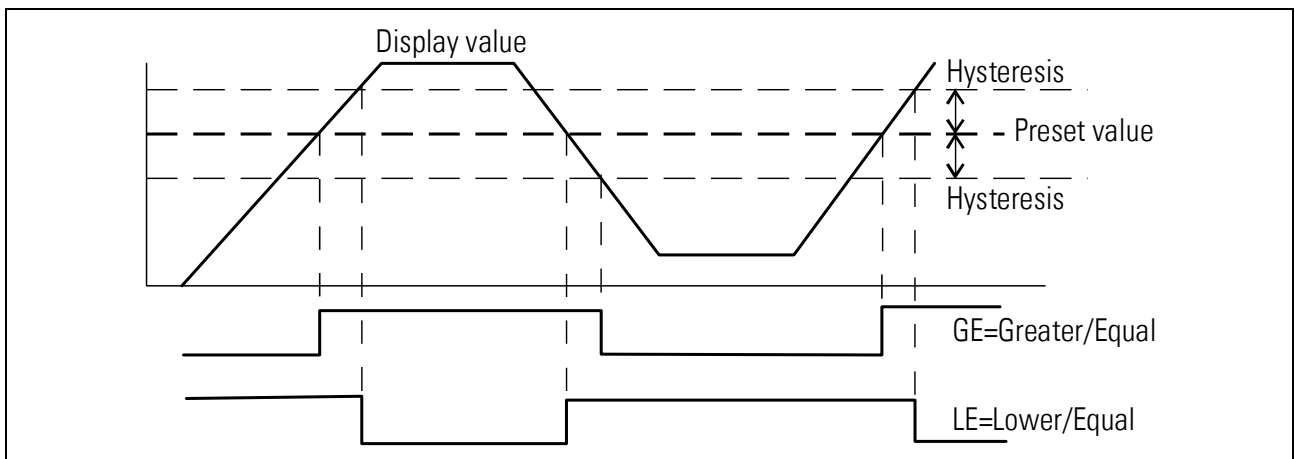

Where the switching outputs have been set to dynamic operation, the output impulse time is always 500 msec. (fixed time, only factory adjustable)

6.4.3. Operational settings for presets:

The settings for the Preselection values appear at the beginning of the operational parameters:

Menu Text	Setting Range	Default
PrES.1 Preselection 1	-99999 ... 99999	10000
PrES.2 Preselection 2	-99999 ... 99999	5000

6.4.4. Actual switching state of the outputs:

At any time you can find out the actual switching state of the outputs. For this, just push the ENTER key shortly during normal operation. The display will then provide one of the following information for the next two seconds:

Display	Meaning
1.2oFF	Both outputs are OFF (output transistors in high impedance state)
1.2oN	Both outputs are ON (output transistors in low impedance state))
1 on	Output 1 is ON Output 2 is OFF
2oN	Output 1 is OFF Output 2 is ON



When Preset 1 is used to monitor a minimum value with setting "LE", and Preset 2 is used to monitor a maximum value with setting "GE", then output 1 will operate with an Automatic Startup-Inhibit, i.e. it will become enabled only after the measuring value has crossed the minimum setting the first time.

Where no startup-Inhibit is desired, please use Preset 1 for Maximum and Preset 2 for Minimum control.

6.4.5. Response time of switching outputs

The response time of the transistor outputs is fully independent of the selected update time for the display. With operating mode "Single" the response time of the outputs is typically 53 msec (provided that average filter and linearization function are switched off)



Use of the average filter and the linearization function will extend the response time of the outputs correspondingly. When the fastest possible response of the outputs is important, please make sure that these two functions are switched off.

6.5. Additional Parameters for the Serial Interface (model AX 348 only)

6.5.1. Communication settings in the Basic Menu:

Menu	Setting Range	Default
<p>S-Unit Unit Number You can assign any unit number between 11 and 99. The address must however <u>not</u> contain a "0" because such numbers are reserved for collective addressing of several units.</p>	0..99	11
<p>S-Form Serial Data Format The first character indicates the number of data bits. The second character specifies the Parity Bit „Even“, "Odd" or no Parity Bit. The third character indicates the number of Stop Bits.</p>	<p>7 E 1 7 E 2 7 0 1 7 0 2 7 no 1 7 no 2 8 E 1 8 0 1 8 no 1 8 no 2</p>	7 E 1
<p>S-bAUD Baud Rate The following Baud Rates can be set for communication:</p>	<p>9600 4800 2400 1200 600 19200 38400</p>	9600

6.5.2. Operational Parameters for configuration of the interface:

Menu		Setting Range	Default																					
S-t int	<p>Serial Timer: Setting 0,000 allows manual activation of a serial data transmission at any time. All other settings specify the cycle time for automatic transmission, when the interface is set to "Printer Mode"</p> <p>Between two transmission cycles the unit will allow a pause depending on the baud rate. The minimum cycle times for timer transmissions are shown in the table.</p> <table border="1"> <thead> <tr> <th>Baud Rate</th> <th>Minimum Cycle Time [ms]</th> </tr> </thead> <tbody> <tr><td>600</td><td>384</td></tr> <tr><td>1200</td><td>192</td></tr> <tr><td>2400</td><td>96</td></tr> <tr><td>4800</td><td>48</td></tr> <tr><td>9600</td><td>24</td></tr> <tr><td>19200</td><td>12</td></tr> <tr><td>38400</td><td>6</td></tr> </tbody> </table>	Baud Rate	Minimum Cycle Time [ms]	600	384	1200	192	2400	96	4800	48	9600	24	19200	12	38400	6	0,000 0,010 sec ... 9.999 sec	0,100 sec					
Baud Rate	Minimum Cycle Time [ms]																							
600	384																							
1200	192																							
2400	96																							
4800	48																							
9600	24																							
19200	12																							
38400	6																							
S-mode	<p>Serial Mode:</p> <p>PC: Operation according to communication profile (see 6.5.3)</p> <p>Print1: Transmission of string type 1 (see 6.5.4)</p> <p>Print2: Transmission of string type 2 (see 6.5.4)</p>	<input type="text" value="PC"/> <input type="text" value="Print 1"/> <input type="text" value="Print 2"/>	<input type="text" value="PC"/>																					
S-Code	<p>Serial Register-Code: Specifies the register code of the data to be transmitted. The most important register codes are:</p> <table border="1"> <thead> <tr> <th>Register</th> <th>S-Code</th> <th>ASCII</th> </tr> </thead> <tbody> <tr><td>Actual display value</td><td>101</td><td>:1</td></tr> <tr><td>Analogue input A *)</td><td>106</td><td>:6</td></tr> <tr><td>Analogue input B *)</td><td>107</td><td>:7</td></tr> <tr><td>Display channel A</td><td>113</td><td>;3</td></tr> <tr><td>Display channel B</td><td>114</td><td>;4</td></tr> <tr><td>Display channel [A,B] combined</td><td>115</td><td>;5</td></tr> </tbody> </table>	Register	S-Code	ASCII	Actual display value	101	:1	Analogue input A *)	106	:6	Analogue input B *)	107	:7	Display channel A	113	;3	Display channel B	114	;4	Display channel [A,B] combined	115	;5	100 ... 120	101
Register	S-Code	ASCII																						
Actual display value	101	:1																						
Analogue input A *)	106	:6																						
Analogue input B *)	107	:7																						
Display channel A	113	;3																						
Display channel B	114	;4																						
Display channel [A,B] combined	115	;5																						

*) Normalized analogue input values, scaling 0 ... 10 000 for 0% to 100% of full scale input signal

6.5.3. PC-Mode

Communication with PC - Mode allows free readout of all parameters and registers of the unit. The subsequent example shows the details of communication for serial readout of the actual display value.

The general string to initiate a request has the following format:

EOT	AD1	AD2	C1	C2	ENQ
EOT = Control Character (Hex 04)					
AD1 = Unit Address, High Byte					
AD2 = Unit Address, Low Byte					
C1 = Register Code, High Byte					
C2 = Register Code, Low Byte					
ENQ = Control Character (Hex 05)					

Example:

Request string for readout of the actual display data from a unit with serial address No. 11:

ASCII-Code:	EOT	1	1	:	1	ENQ
Hexadecimal:	04	31	31	3A	31	05
Binary	0000 0100	0011 0001	0011 0001	0011 1010	0011 0001	0000 0101

With a correct request the unit will respond with the adjoining response string. Leading zeros will be suppressed. BCC provides a „Block Check Character“, formed by Exclusive-OR of all characters from C1 through ETX.

STX	C1	C2	x x x x x x x	ETX	BCC
STX = Control Character (Hex 02)					
C1 = Register Code, High Byte					
C2 = Register Code, Low Byte					
x x x x x = Data (display value)					
ETX = Control Character (Hex 03)					
BCC = Block Check Character					

With inaccurate request strings the unit would only respond "STX C1 C2 EOT" or just "NAK".

Assumed that the actual display value is "-180", the response of the unit would be

ASCII	STX	:	1	-	1	8	0	ETX	BCC
Hex	02	3A	31	2D	31	38	30	03	1C
Bin	0000 0010	0011 1010	0011 0001	0010 1101	0011 0001	0011 1000	0011 0000	0000 0011	0001 1100

Again, the block check character "BCC" is calculated from the Exclusive-OR of all characters from C1 through ETX.

6.5.4. Printer Mode

The Printer Mode allows cyclic or manual activation of transmissions of the specified register data. The corresponding register can be specified by means of parameter „S-Code“.

Another parameter named „S-mod“ allows selection between two different string types:

„S-mod“	Transmission String Type									
„Print1“	Space	Sign	Data						Line feed	Carriage return
		+/-	X	X	X	X	X	X	LF	CR
„Print2“	Sign	Data						Carriage return		
	+/-	X	X	X	X	X	X	CR		

The mode of activation of serial transmissions can be determined as follows:

Cyclic (timed) transmissions:	Set the Serial Timer to any value ≥ 0.010 sec. Select the desired string type by parameter "S-mod" After exit from the menu the transmissions will start automatically
Manual activation of transmissions	Set the Serial Timer to 0.000. Select the desired string type by parameter "S-mod" After exit from the menu a transmission can be activated at any time by shortly pressing the ENTER key

7. Commissioning

Commissioning of this unit is easy and uncomplicated when following the subsequent steps:

	Step	Action	See section
1	Analogue inputs	<ul style="list-style-type: none">• Set jumpers	3
2	Basic settings	<ul style="list-style-type: none">• Select Operation mode• Keep linearization and Tare function off firstly	6.1 6.1
3	Parameter settings	<ul style="list-style-type: none">• Configuration of the analogue inputs, scaling of the display• Select combination and final scaling (if applicable)• Configuration of switching outputs (AX 347) (if applicable)• Configuration of the serial interface	6.3.1 and 6.3.2 6.3.3 6.4 6.5
4	Supplementary functions	<ul style="list-style-type: none">• Set Tare function and Linearization (if applicable)	8

A Set-Up Form is available in the appendix of this manual, which may be used for a most convenient and clearly arranged setup procedure.

It is advisable to do settings for Tare and linearization functions quite at the end, after all other functions have already proved to work fine.

8. Special Functions

8.1. Tare / Offset function

This function will become active after the "Cmd" parameter has been set to "oFFSEt" or to "both"(see 6.1). As a result, every touch of the "Cmd" key will store the actual display value to the Offset register, resulting in a Zero display with the actual input signal.

8.2. Linearization

This function allows converting non-linear input signals into a linear presentation or vice-versa. There are 16 interpolation points available, which can be freely arranged over the whole measuring range in any distance. Between two points the unit automatically will interpolate straight lines.

For this reason it is advisable to set many points into areas with strong bending, and to use only a few points in areas with little bending. „Linearization Mode“ has to be set to either „1-quA“ or „4-quA“ to enable the linearization function (see subsequent drawing). This will change the linear measuring results into a non-linear display.

Parameters **P01_x** to **P16_x** select 16 x-coordinates, representing the display values which the unit would normally show in the display. With parameters **P01_y** to **P16_y** you can specify now, which values you would like to display instead of the corresponding _x values.

This means e.g. that the unit will replace the previous P02_x value by the new P02_y value.



- With respect to the consistency of the linearization, the x- registers have to use continuously increasing values, e.g. the x- registers must conform to the constraint $P01_X < P02_X < \dots < P15_X < P16_X$.
- Independent of the selected linearization mode, the possible setting range of all registers P01_x, P01_y, ..., P16_x, P16_y is always -99999 ... 99999.
- For measuring values lower than P01_x, the linearization result will always be P01_y.
- For measuring values higher than P16_x, the linearization result will always be P16_y.
- With operation modes "Single" and "Dual", all linearization refers to input channel A only.
- With all combined operation modes, linearization refers to the calculated final result of the selected combination.

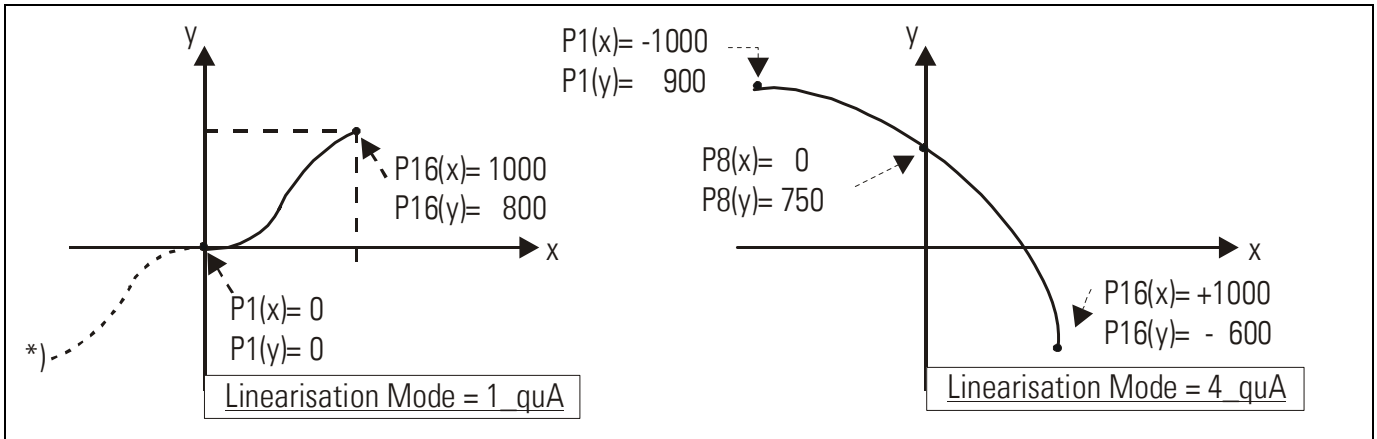

Application Example:

We like to display the filling quantity (volume) of a tank as shown below, with use of a pressure sensor mounted to the bottom of the tank. With this application the analogue pressure signal is proportional to the filling level, but not to the filling quantity.

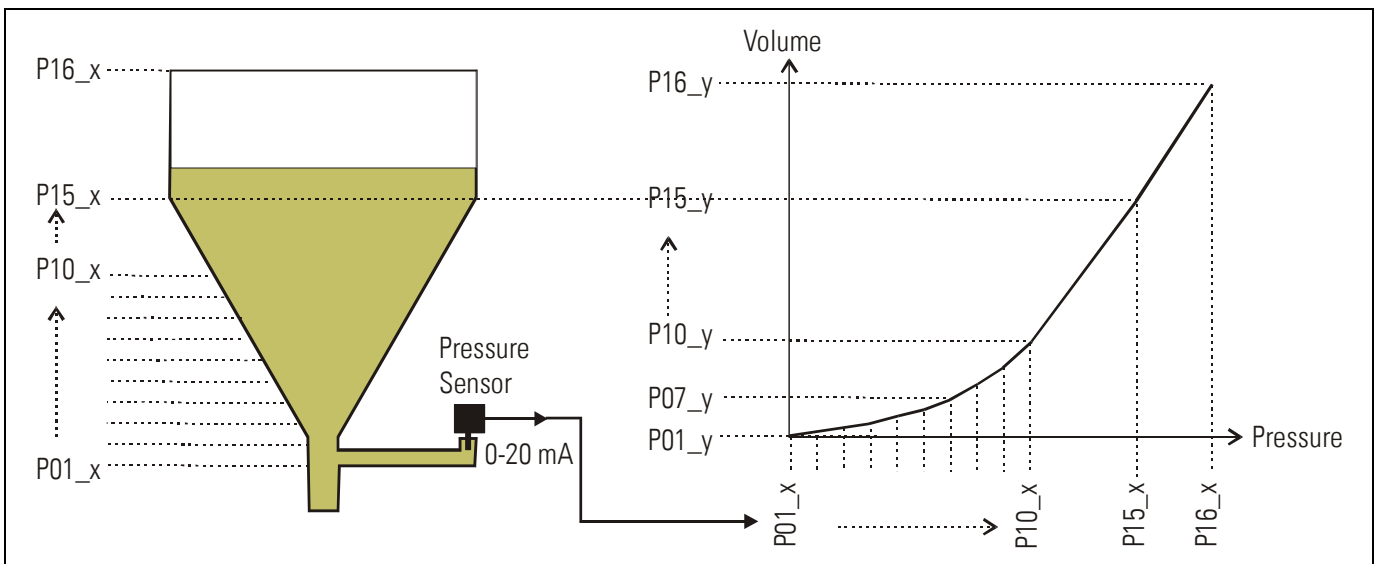

To solve the problem, we divide the non-linear part of the tank into 14 parts. We enter the expected display values of the pressure sensor to registers P01_x to P15_x. For the linear part of the tank it is sufficient to store the final pressure value to register P16_x. Now we can easily calculate the appropriate filling quantities and enter these values to the registers P01_y to P16_y.

8.3. Manual input or „Teaching“ of the interpolation points

Interpolation points to form the linearization curve can be entered one after another, using the same procedure as for all other numeric parameters. This means you will enter all parameters P01_x to P16_x and P01_y to P16_y manually by keypad.



During manual input of interpolation points the unit will not examine the settings P01_x to P16_x. Therefore the operator is responsible to observe the constraint

$$P01_X < P02_X < \dots < P15_X < P16_X.$$

In many cases it should however be more convenient to use the Teach function. Here you have to sequentially apply all the x-values to the analogue input, and just add the corresponding y-values by keypad.

Preparation for teaching:

- Please select the desired range of linearization (see section 6.1).
- Please set the basic parameter „Cmd“ to „tEACH“ or „both“ (see section 6.1).
After this, the teach function is ready to start.

How to use the Teach Function:

- Hold down the „Cmd“ key for 3 seconds, until the display shows „tEACH“. Now you are in the Teach mode.

To exit the teach mode again, you have the following two possibilities:

1. Press the enter key for 2 seconds. On the display you will read „StOP“ for a short time, and then the unit will switch back to the normal mode.
2. Just do nothing. After 10 seconds the unit will switch back to the normal mode automatically. In both cases the parameters of linearization P01_X to P16_Y will not change.

- To start the teach procedure please press „Cmd“ again within the next 10 seconds. The display will show „P01_X“.



With respect to the consistency of the linearization, all parameters from P01_X to P16_Y will be overwritten by suitable initial values.

Initial values for „P01_X“ and „P01_Y“ are -99999, all other values will start with 99999

- Press once more „Cmd“ to display the actual analogue input signal. Now arrange for the desired analogue input signal of the first interpolation point (with combined modes please arrange for both analogue signals)

- When you read the x-value of your first interpolation point in the display, press “Cmd” again. This will automatically store the actual display value to the P01_x register, and for about 1 second you will read “P01_y ” on the display, followed again by the same reading stored previously.
- This display value now can be edited to the desired P01_y value, like a regular parameter
- When you read the desired P01_y value in your display, store it by pressing “Cmd” again. This will automatically cycle the display to the next interpolation point P02_x.



The unit will examine the constraint valid for the x-values of interpolation points. Every interpolation point must be higher than its preceding point.

Where this constraint is breached, all 6 decimal points will blink automatically as a warning. Pressing the CMD key will not store the illegal value, but result in an error text "E.r.r.-.L.O." as a warning.

- Once you have reached and stored the last interpolation points P16_x/y, the routine will restart with P01_x again, and you are free to double-check your settings once more.
- To conclude the Teach procedure, press the ENTER key. As a result you will read “StOP” for about 2 seconds, before the unit returns to the normal operation. All linearization points will at the same time be finally stored.

8.4. Overflow and Underflow Control

The unit continuously monitors both input channels for possible overflow or underflow situations (input signal out of specified range)

Overflow: the analogue input signal is greater than +10,2 V or +20,4 mA

Underflow: the analogue input signal is lower than -10,2 V or -0,4 mA

Any out-of-range situation will cause a message according the table below:

Display	Input A	Input B
1Lo	Underflow	o.k
1Hi	Overflow	o.k
2Lo	o.k	Underflow
2Hi	o.k	Overflow
1Lo2Lo	Underflow	Underflow
1Hi2Lo	Overflow	Underflow
1Lo2Hi	Underflow	Overflow
1Hi2Hi	Overflow	Overflow

9. Technical Specifications

9.1. Dimensions

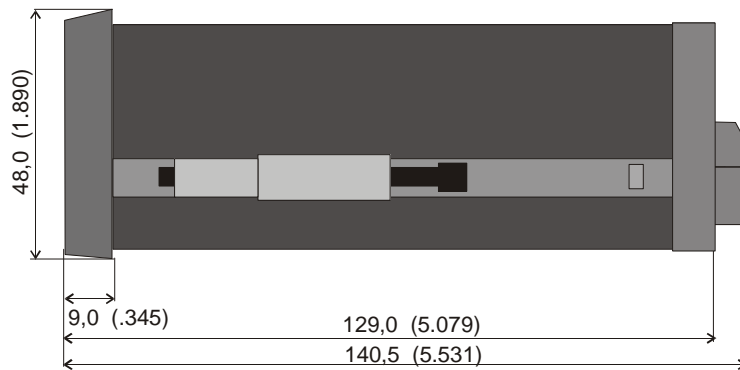
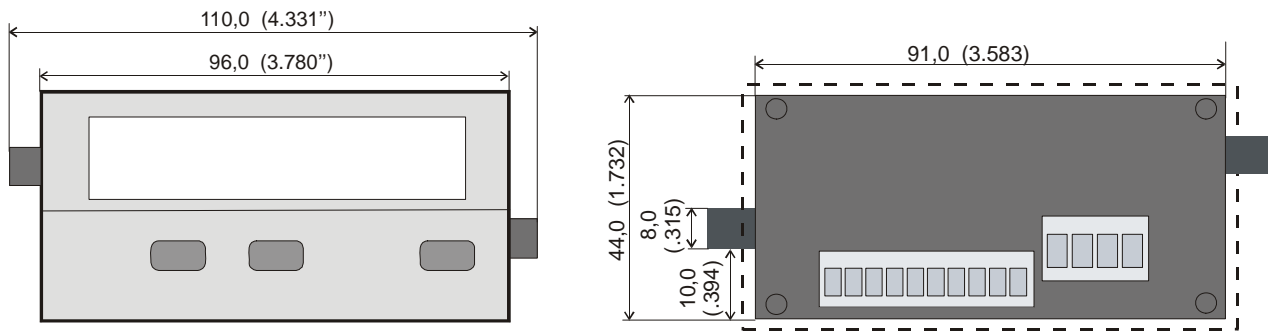

Panel cut out: 91 x 44 mm (3.583 x 1.732")

9.2. Technical data

Power supply AC	: 115/230 V (+/- 12,5 %), 7,5 VA
Power supply DC	: 24 V (17 – 30 V), approx. 100 mA (without aux. sensor supply)
Total AC power	: 7,5 VA
DC current consumption (without sensors)	: 18 V : 110 mA, 24 V : 90 mA, 30 V : 80 mA
Aux. output for sensors	: 24 V DC, +/- 15%, 100 mA (with AC and DC power input)
Inputs	: 2 analogue inputs (+/-10 V, 0 ... +20 mA, 4 ... +20 mA)
Input impedance	: Current: Ri = 100 Ohms, Voltage: Ri = 30 kOhms
Resolution	: 14 bits (13 bits + sign)
Accuracy	: +/- 0.1%, +/- 1 digit
Switching outputs (AX 347 only)	: 2 x PNP, max. 35 V, max. 150 mA minimum response time 53 msec.
Serial interface (AX 348 only)	: RS 232 / RS 485, 600 - 38 400 bauds
Ambient temperature	: Operation: 0° - 45° (32 – 113°F) Storage: -25° - +70° (-13 – 158°F)
Housing	: Norly UL94 – V-0
Display	: 6 decades LED, high-efficiency orange, 15 mm (0.590")
Protection class	: IP65 (front), IP20 (rear)
Screw terminals	: Signal lines max. 1.5 mm ² (.0023 sq.in.) AC lines max. 2.5 mm ² (.0039 sq.in.)
Minimum update time	: 50 msec (display) : 53 msec (switching outputs)
Conformity and standards	: EMC 2004/108/EC: EN 61000-6-2 EN 61000-6-3 LV 2006/95/EC: EN 61010-1

9.3. Commissioning Form

Date:	Software:
Operator:	Serial No.:

Basic Settings:	Operating mode:	Code:
	Brightness:	Linearization:
	Display Update [sec]:	Cmd key command:
Model AX347	Source 1:	Source 2:
	Switch characteristics 1:	Switch characteristics 2:
	Hysteresis 1:	Hysteresis 2:
Model AX348	Serial unit No.:	Serial format:
	Serial Baud Rate:	

Analogue Inputs:		Input A	Input B
	Input range:		
	Start value:		
	End value:		
	Decimal point:		
	Filter:		
	Offset :		

Combined modes: (A+B, A-B, A:B, AxB)	Proportional factor:	
	Reciprocal factor:	
	Additive constant:	
	Decimal point:	

Additional parameters:		
Model AX347	Preselection 1:	Preselection 2:
Model AX348	Serial Timer [s]:	Serial Mode:
	Serial Code:	

