

# AX 321, AX 323

## Process Indicators for Strain Gauge Inputs with 2 Presets/Relays and Totalizer Function



Model AX 321: Power supply 10 – 30 VDC

Model AX 323: Power supply 90 – 240 VAC and auxiliary output 24 VDC

- Two models with different power supply range, but otherwise fully identical
- Signal input for strain gauges  
(3.3 mV/V, 3.0 mV/V, 2.0 mV/V, 1.5 mV/V and 1.0 mV/V)
- Two relay outputs for limit monitoring (dry changeover contacts)
- Two digital multi-function inputs with programmable control function
- Useful supplementary functions like Digital Filter, Linearization, Totalizer etc.
- 6 digit 14-segment display (14 mm / 0.55" size) for readout and menu dialogues

## Operating Instructions



## Safety Instructions

- This manual is an essential part of the unit and contains important hints about function, correct handling and commissioning. Non-observance can result in damage to the unit or the machine or even in injury to persons using the equipment!
- The unit must only be installed, connected and activated by a qualified electrician
- It is a must to observe all general and also all country-specific and application-specific safety standards
- When this unit is used with applications where failure or maloperation could cause damage to a machine or hazard to the operating staff, it is indispensable to meet effective precautions in order to avoid such consequences
- Regarding installation, wiring, environmental conditions, screening of cables and earthing, you must follow the general standards of industrial automation industry
- - Errors and omissions excepted –



General instructions for cabling, screening and grounding can be found in the SUPPORT section of our website <http://www.motrona.com>

Version:	Description
AX32101a/hk/01_2012	First edition

# Table of Contents

<b>1.</b>	<b>Short Form Description.....</b>	<b>4</b>
<b>2.</b>	<b>Display and Operating Elements .....</b>	<b>5</b>
2.1	Overview .....	5
2.2	Special Key Functions .....	5
<b>3.</b>	<b>Block Diagram and Terminal Assignments.....</b>	<b>6</b>
<b>4.</b>	<b>Operating Concept (Mode of Operation).....</b>	<b>7</b>
<b>5.</b>	<b>Programming .....</b>	<b>8</b>
5.1	How to Enter the Menu / Select a Function Group / Quit the Menu:.....	8
5.2	How to Select Functions / Set Parameters / Accept Settings .....	9
<b>6.</b>	<b>Function Groups.....</b>	<b>10</b>
6.1	Help Texts (running text).....	10
6.2	Signal Inputs.....	10
6.3	User Linearization.....	11
6.4	Multifunction Key (MP-Key) and Multifunction inputs (MP-INP).....	14
6.5	Totalizer Function .....	17
6.6	Limit Value (Alarm) Monitoring .....	18
6.7	Monitoring of the Measuring Circuit.....	21
<b>7.</b>	<b>Technical Specifications.....</b>	<b>22</b>
<b>8.</b>	<b>Dimensional Drawings .....</b>	<b>24</b>
<b>9.</b>	<b>Help Texts .....</b>	<b>25</b>

# 1. Short Form Description

The units of series AX 321 and AX 323 have been designed for digital readout and monitoring of measuring values with industrial applications of automation.

Model AX 321 provides a power supply input of 24 VDC.

Model AX 323 provides a power supply input of 90 – 240 VAC and offers an additional auxiliary output with 24 VDC / 30 mA for sensor supply purpose.





All further properties of these two models are fully identical.

The subsequent list shows a summary of technical specifications of both units:







- 6-digit 14-segment LED display, 14 mm, for displaying measured values and dialogs
- Running text can be switched on as Help Text
- Language for the Help Text selectable as English or German
- Signal input for strain gauges 3.3 mV/V, 3.0 mV/V, 2.0 mV/V, 1.5 mV/V and 1.0 mV/V
- Sampling rate 10 readings per second
- Digital filter (1st order) for smoothing display fluctuations with unstable input signals
- Customized linearization
- MIN/MAX memory function
- Totalizer function
- 2 Relay outputs (changeover contacts) for limit monitoring
- Start delay for relay outputs after Power ON
- Versions for supply voltage 10 ... 30 V DC and 90 ... 260 V AC
- Auxiliary power supply 10 V DC / 30 mA
- Additional aux. power output 24 V / 30 mA with AC supply
- Programmable via the front keys
- Multifunction key and two multifunction inputs, function programmable

## 2. Display and Operating Elements

### 2.1 Overview

<p><b>(1) Display</b>          - 14 segment display, 6-digit, red          - Height of figures 14 mm</p>	
<p><b>(2) Status display</b> ( 2 LED annunciators, red)          - Switching status of Alarm 1 and Alarm 2          - Indication Function Group or Function</p>	
<p><b>(3) MP-Key and Programming Keys</b></p>	
<p> - Multifunction key (MP-Key)</p>	
<p> - Return from Function Group          - Return from Function</p>	
<p> - Select previous Function Group          - Select previous Function          - Decrement parameter value</p>	
<p> - Select next Function Group          - Select next Function          - Increment parameter value</p>	
<p> - Enter a Function Group          - Enter a Function          - Accept the new setting</p>	
<p><b>(4) Space for unit overlay</b></p>	

### 2.2 Special Key Functions

To enter the Programming Menu:	 +  [ $> 3 \text{ sec}$ ]
To display Device Type and Software Version:	 +  +  [ $> 5 \text{ sec}$ ]
To restore factory default settings:	 +  [ $> 3 \text{ sec}$ ]

### 3. Block Diagram and Terminal Assignments

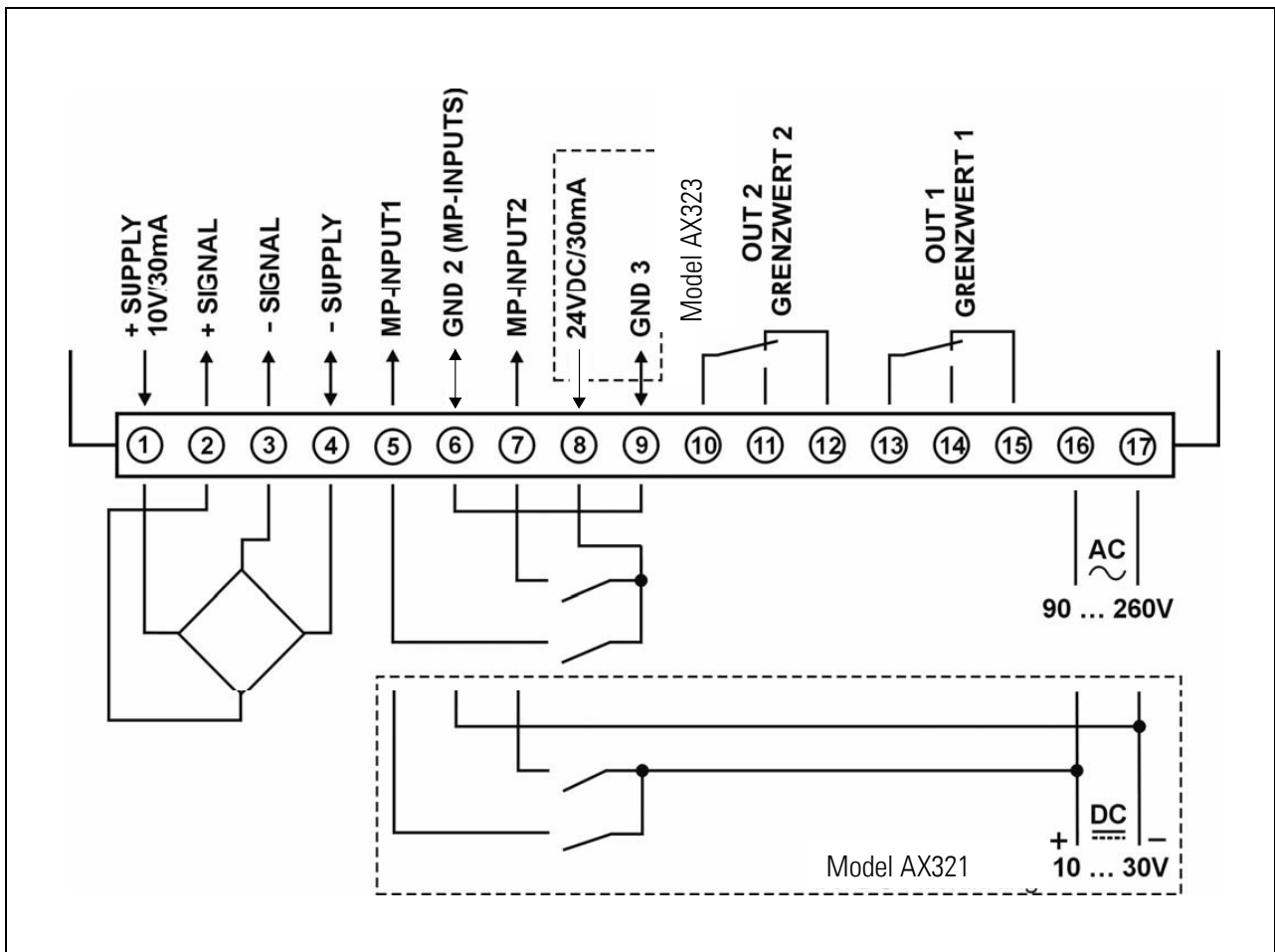
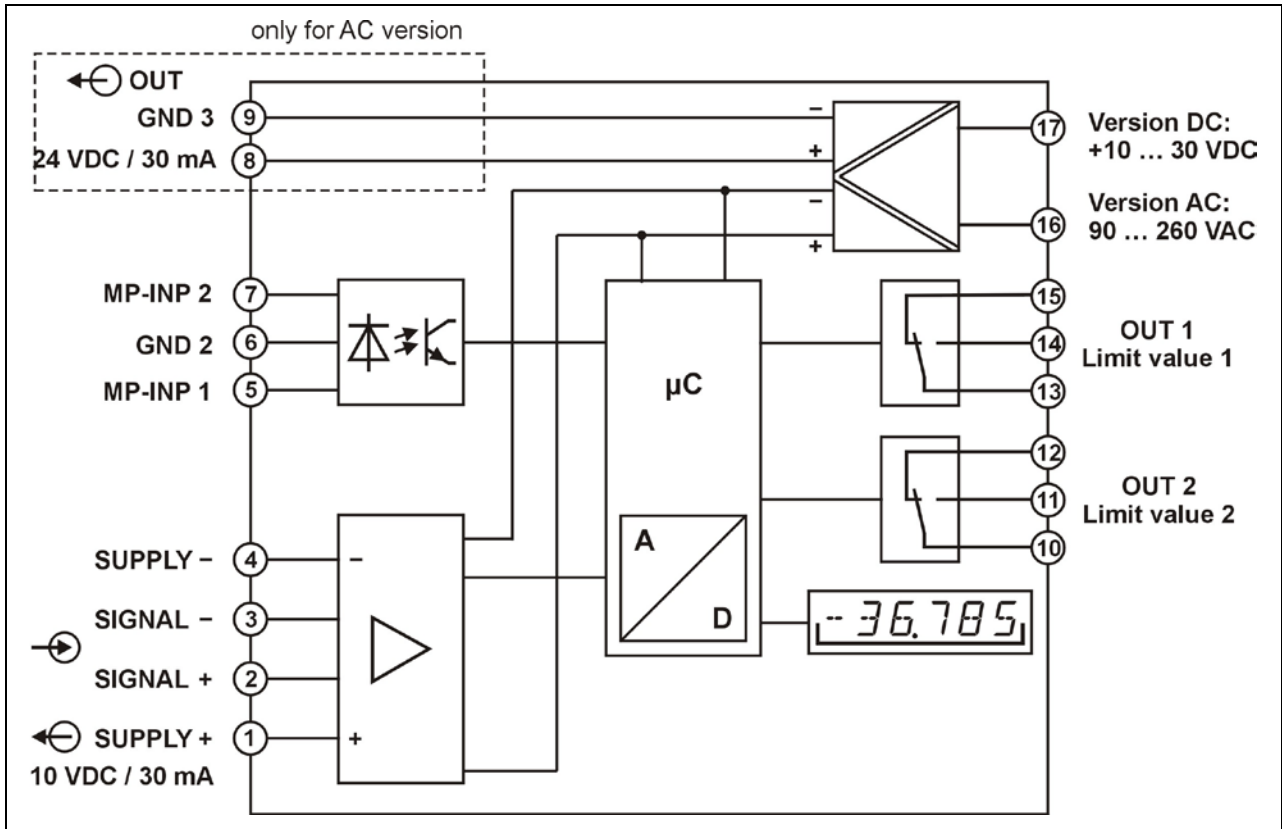



# 5. Programming



- To enter the programming menu: **-** + **+** [ $> 3$  sec]
- During programming the relays are inactive (not energized)
- When quitting the programming menu via **SAVE**, the minimum and maximum values and the totalizer value are all cleared.

## 5.1 How to Enter the Menu / Select a Function Group / Quit the Menu:

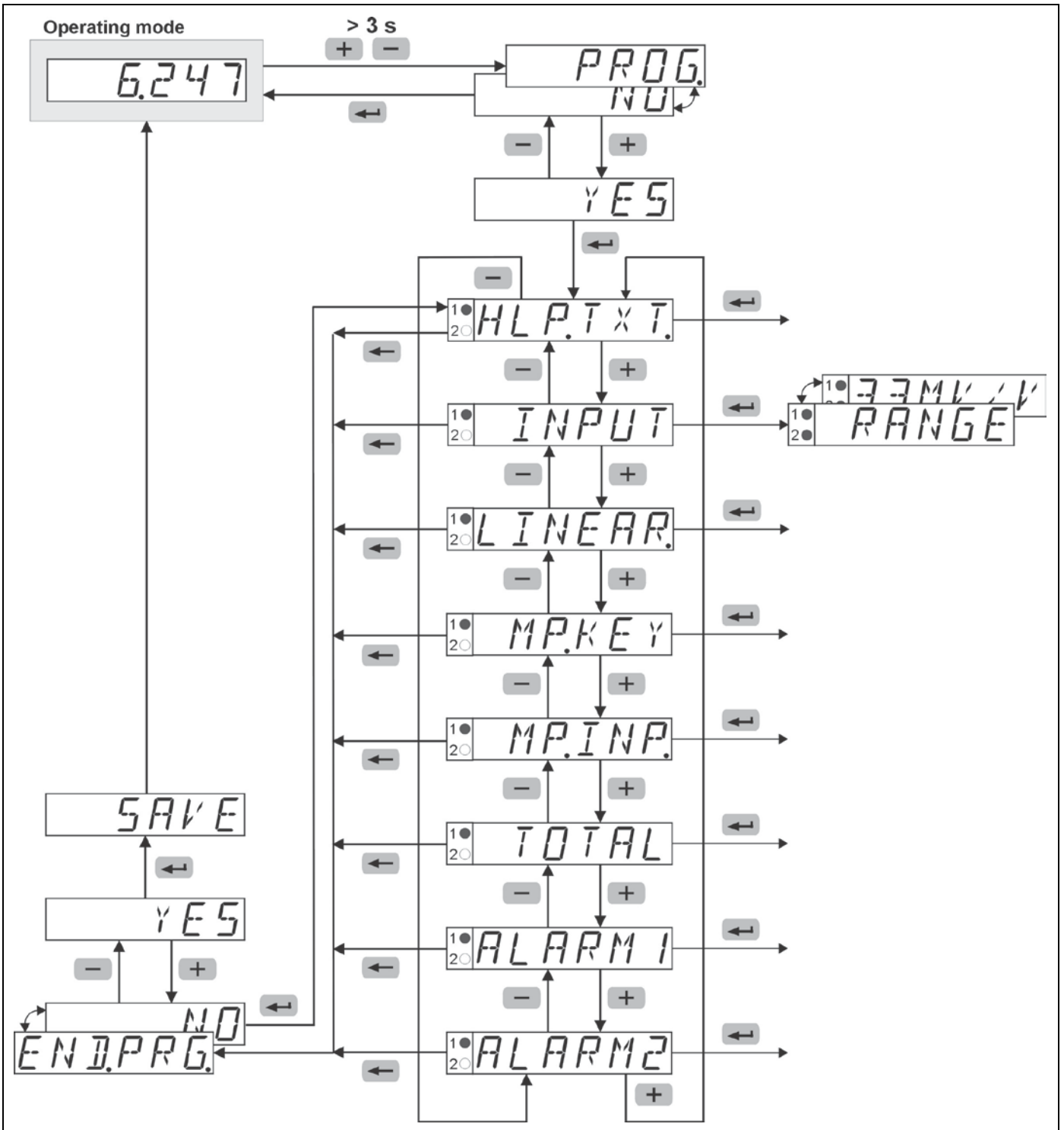



## 5.2 How to Select Functions / Set Parameters / Accept Settings

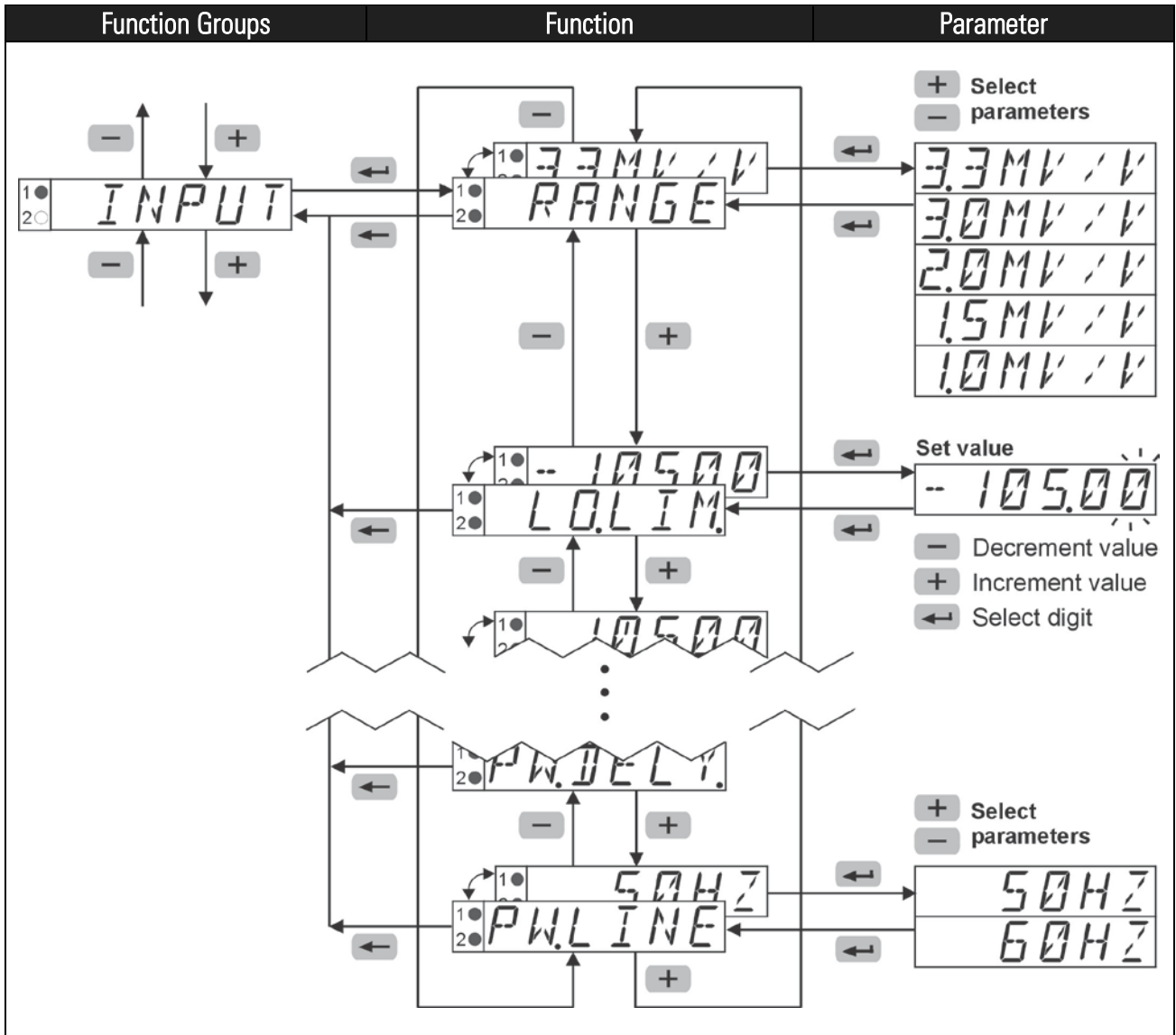

## 6. Function Groups



In the subsequent chapters the Factory Default Settings are highlighted by grey color.

### 6.1 Help Texts (running text)

<i>HLP.TXT</i>	Help Text Menu
<i>HLP.TXT</i>	Select Help Text
<i>ON</i>	ON: running texts that have started can be aborted by any programming key
<i>OFF</i>	OFF
<i>SL.LANG.</i>	Select Language for Help Texts
<i>EN</i>	English
<i>DE</i>	Deutsch (German)

### 6.2 Signal Inputs

<i>INPUT</i>	Menu Input Signal
<i>RANGE</i>	Select measuring range
<i>0 - 10V</i>	Sensitivity 3.3 mV/V
<i>2 - 10V</i>	Sensitivity 3.0 mV/V
<i>- 10.10V</i>	Sensitivity 2.0 mV/V
<i>0 - 20mA</i>	Sensitivity 1.5 mV/V
<i>4 - 20mA</i>	Sensitivity 1.0 mV/V
<i>LO.LIM.</i>	Select lower measuring range limit
<i>- 0.500</i>	Setting range 0.00 ... -105.00 [%]
<i>HIL.LIM.</i>	Select upper measuring range limit
<i>10.500</i>	Setting range 0.00 ... +105.00 [%]
<i>DP.</i>	Select Decimal Point (visual function only)
<i>0.000</i>	0 - 0.0 - 0.00 - 0.000 - 0.0000
<i>INP.LO.</i>	Select input low value
<i>0.000</i>	Setting range -105.00 ... +105.00 [%]
<i>DISP.LO.</i>	Select low display value for INP.LO.
<i>0.000</i>	Setting range -199999 ... +999999 and decimal point

INP.HI.	Select input high value
10.000	Setting range -105.00 ... +105.00 [%]
DISP.HI.	Select high display value for INP.HI.
10.000	Setting range -199999 ... +999999 and decimal point
FILTER	Select input filter: (number of measuring cycles for floating average calculation)
1	Setting range 1 ... 99 [cycles], with setting 1 the filter is turned off
PW.DEL.Y.	Select start delay after power on (limit monitoring is processed only after the programmed time has expired)
0.0	Setting range 0.0 ... 99.9 [sec]
PW.FREQ	Select local mains frequency
50HZ	Mains frequency 50 Hz
60HZ	Mains frequency 60 Hz



- The input range for the input values is entered in %.  
Clarification: with a sensor supply voltage of 10 V and a sensor sensitivity of 3.3 mV / V, a sensor output of 33 mV equates to an input value of 100 %.
- The functions LO.LIM and HI.LIM will limit the editable range correspondingly.
- The setting of HI.LIM has to be greater than the setting of LO.LIM at any time.

### 6.3 User Linearization

LINEAR.	Menu User-Linearization
LINEAR.	Select User Linearization
NO	Linearization OFF
YES	Linearization ONF
NUM.PNT.	Select number of interpolation points
3	Setting range 3 ... 12 points
INP.LO.	Select input low value
-- 100.00	Setting range -105.00 ... +105.00 [%]
DISP.LO.	Select display low value for INP.LO.
-- 100.00	Setting range -199999 ... +999999 and decimal point.

INP.01	Select input value 1
0.00	Setting range -105.00 ... +105.00 [%]
DISP.01	Select display value for INP.01.
0.00	Setting range -199999 ... +999999 and decimal point.
INP.10	Select input value 10
0.00	Setting range -105.00 ... +105.00 [%]
DISP.10	Select display value for INP.10.
0.00	Setting range -199999 ... +999999 and decimal point.
INP.HI.	Select input high value
100.00	Setting range -105.00 ... +105.00 [%]
DISP.HI.	Select display value for INP.HI.
100.00	Setting range -199999 ... +999999 and decimal point.



- A maximum of 12 linearization points is possible.
- An input value INP must be entered for each linearization point (LP) (input of the sensor value from the analogue input in physical units) as well as the corresponding display value DISP for this sensor value.
- The linearization points (LP) may be entered in any order. They are then sorted in the firmware in ascending order for the linearization function.
- Linearization based on a negative slope is possible.
- The input range for the input values is entered in %.  
Clarification: with a sensor supply voltage of 10 V and a sensor sensitivity of 3.3 mV / V, a sensor output of 33 mV equates to an input value of 100 %.
- The functions LO.LIM and HI.LIM limit the editable range.  
The value for HI.LIM must always be greater than the value for LO.LIM.

### 6.3.1 Example for linear scaling

**Example1:** -100%...+100% = -600...600, **Example2:** -60%...+80% = 300...-400, **Example3:** 0%...+100% = 400...700

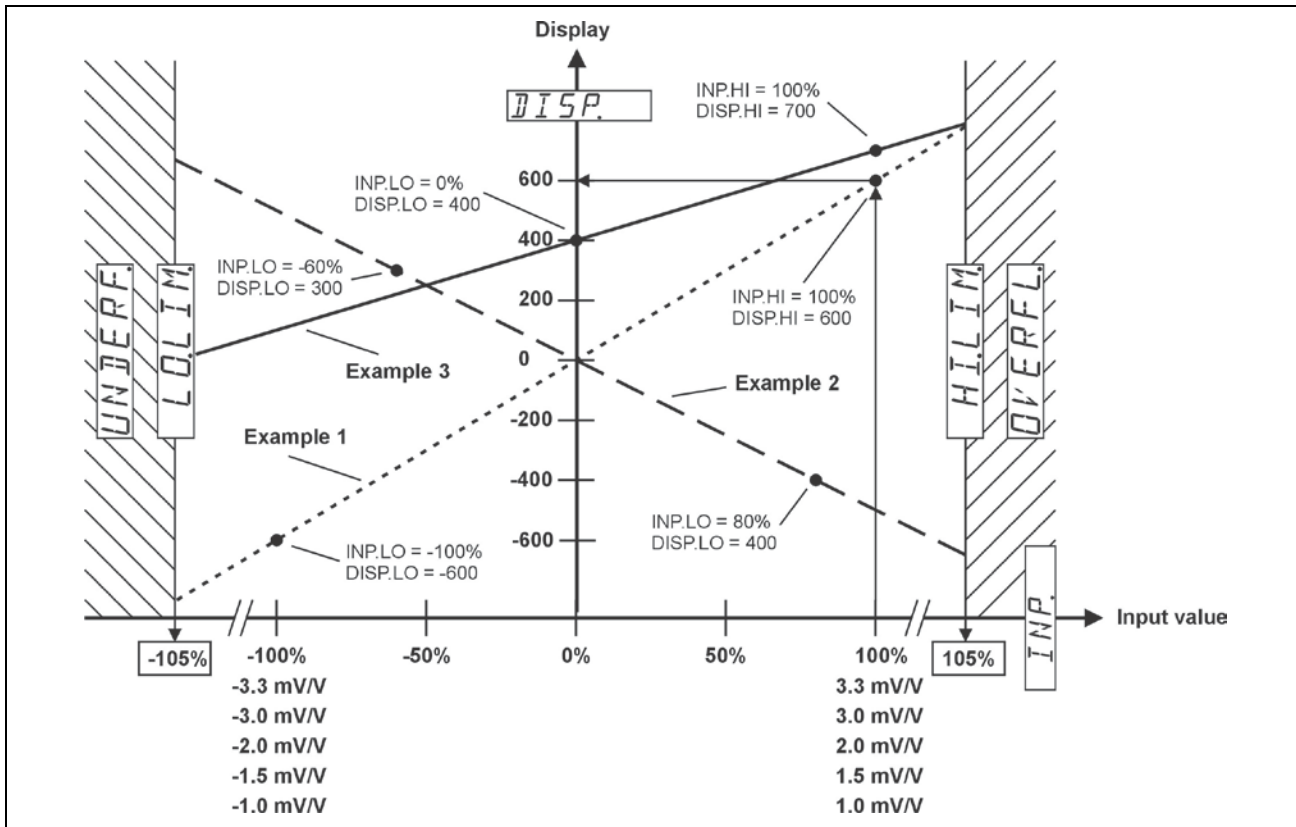

### 6.3.2 Example for non-linear scaling

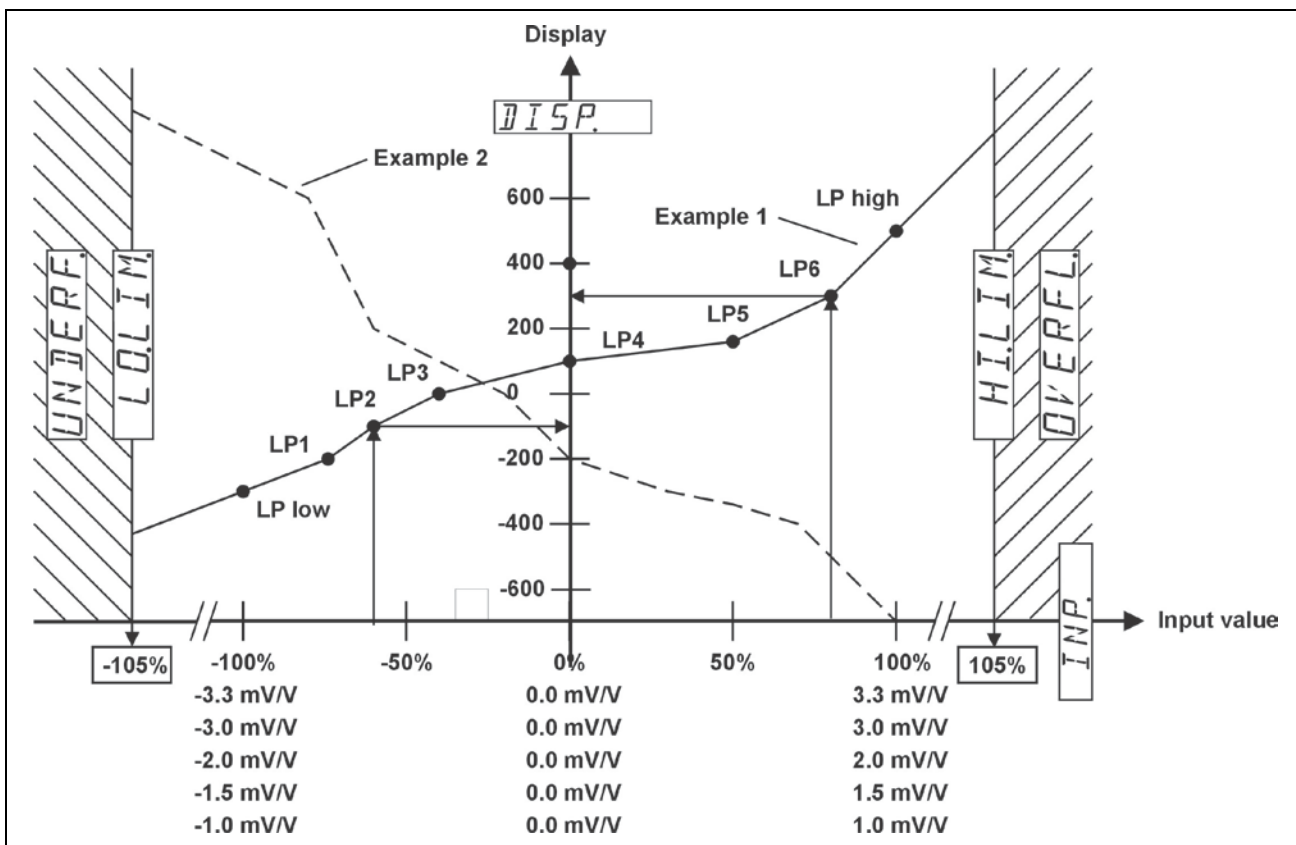

## 6.4 Multifunction Key (MP-Key) and Multifunction inputs (MP-INP)

### Tare

- In the function group MP.KEY, programme the function TARA to ON. In the operating mode select the current measured value (ACTUAL) and briefly press the MP Key.
- In the function group MP.INP, programme the function MP.INP1 or MP.INP2 to TARA. In the operating mode briefly activate the multifunction input 1 or multifunction input 2

### Reset Tare Value

- In the function group MP.KEY, programme the function TARA to ON. In the operating mode select the current measured value (ACTUAL) and press the MP Key >5 sec.
- In the function group MP.INP, programme the function MP.INP1 or MP.INP2 to R.TARA. In the operating mode briefly activate the multifunction input 1 or multifunction input 2.

### Reset MIN value memory

- In the function group MP.KEY, programme the function RES.MIN to ON. In the operating mode select the minimum value memory (MINIMU) and briefly press the MP Key.
- In the function group MP.INP, programme the function MP.INP1 or MP.INP2 to RES.MIN or R.PEAKS. In the operating mode briefly activate the multifunction input 1 or multifunction input 2.

### Reset MAX value memory

- In the function group MP.KEY, programme the function RES.MAX to ON. In the operating mode select the maximum value memory (MAXIMU) and briefly press the MP Key.
- In the function group MP.INP, programme the function MP.INP1 or MP.INP2 to RES.MAX or R.PEAKS. In the operating mode briefly activate the multifunction input 1 or multifunction input 2.

### Reset of relay outputs in Latch mode

- In the function group MP.KEY, programme the function RES.REL to ON. In the operating mode briefly press the MP Key.
- In the function group MP.INP, programme the function MP.INP1 or MP.INP2 to RES.REL. In the operating mode briefly activate the multifunction input 1 or multifunction input 2.

### Adopt new measured value for Totalizer

- In the function group MP.KEY, programme the function ACK.TOT to ON. In the operating mode select the totalizer (TOTAL) and briefly press the MP Key.
- In the function group MP.INP, programme the function MP.INP1 or MP.INP2 to ACK.TOT. In the operating mode briefly activate the multifunction input 1 or multifunction input 2.

### Reset Totalizer

- In the function group MP.KEY, programme the function RES.TOT to ON. In the operating mode, select the totalizer (TOTAL) and briefly press the MP Key.
- In the function group MP.INP, programme the function MP.INP1 or MP.INP2 to RES.TOT. In the operating mode briefly activate the multifunction input 1 or multifunction input 2

## Display Hold

- In the function group MP.INP, programme the function MP.INP1 or MP.INP2 to DISP.HD.
- In the operating mode, select either the current measured value (ACTUAL) or the totalizer (TOTAL) and activate multifunction input 1 or multifunction input 2.

## Lock-out Limit Value (Alarm) setting

- In the function group MP.INP, programme the function MP.INP1 or MP.INP2 to LOC.ALR.
- In the operating mode, activate multifunction input 1 or multifunction input 2

## Lock-out Programming and Default setting

- In the function group MP.INP, programme the function MP.INP1 or MP.INP2 to LOC.PRG.
- In the operating mode, activate multifunction input 1 or multifunction input 2.

## Lock-out Keypad

- In the function group MP.INP, programme the function MP.INP1 or MP.INP2 to LOC.KEY.
- In the operating mode, activate multifunction input 1 or multifunction input 2.

### 6.4.1 Multifunction Key

<i>MP.KEY</i>	Menu Function MP key
<i>TARA</i>	Select function: Reset Tare by MP key (when current measuring value is in display)
<i>OFF</i>	OFF
<i>ON</i>	ON
<i>RES.MIN.</i>	Select function: Reset MIN value by MP key (when MIN value is in display)
<i>OFF</i>	OFF
<i>ON</i>	ON
<i>RES.MAX.</i>	Select function: Reset MAX value by MP key (when MAX value is in display)
<i>OFF</i>	OFF
<i>ON</i>	ON
<i>RES.REL.</i>	Select function: Output Latch Reset by MP key (only if output is in memory mode, ALARMx = LATCH)
<i>OFF</i>	OFF
<i>ON</i>	ON (this setting is possible only if all other settings are set to OFF)
<i>RES.TOT.</i>	Select function: Reset Totalizer by MP key (when the totalizer value is in display)
<i>OFF</i>	OFF
<i>ON</i>	ON
<i>ACK.TOT.</i>	Select function: Adopt new value for totalizer (when totalizer appears in the display)
<i>OFF</i>	OFF
<i>ON</i>	ON (setting is possible only if RST.TOT = OFF)

## 6.4.2 Multifunction Inputs

<i>MP.INP.</i>	Menu Function MP Inputs
<i>MP.INP.1</i>	Select function MP input 1
<i>NO.FUNC.</i>	No function
<i>RES.MIN.</i>	Reset MIN value
<i>RES.MAX.</i>	Reset MAX value
<i>R.PEAKS</i>	Reset MIN and MAX values
<i>RES.REL.</i>	Reset Output-Latch (only if output is in memory mode,ALARMx = LATCH)
<i>DISP.HD.</i>	Hold ('freeze') display
<i>LOCALR.</i>	Lock-out limit value setting
<i>LOC.PRG.</i>	Lock-out programming and default setting
<i>LOCKEY</i>	Lock-out limit value setting, programming, default setting and MP-Key
<i>TARA</i>	Tare
<i>R.TARA</i>	Reset tare value
<i>RES.TOT.</i>	Reset totalizer
<i>ACK.TOT.</i>	New value for totalizer
<i>MP.INP.2</i>	Select function MP input 2
<i>NO.FUNC.</i>	No function
<i>RES.MIN.</i>	Reset MIN value
<i>RES.MAX.</i>	Reset MAX value
<i>R.PEAKS</i>	Reset MIN and MAX values
<i>RES.REL.</i>	Reset Output-Latch (only if output is in memory mode, ALARMx = LATCH)
<i>DISP.HD.</i>	Hold ('freeze') display
<i>LOCALR.</i>	Lock-out limit value setting
<i>LOC.PRG.</i>	Lock-out programming and default setting
<i>LOCKEY</i>	Lock-out limit value setting, programming, default setting and MP-Key
<i>TARA</i>	Tare
<i>R.TARA</i>	Reset tare value
<i>RES.TOT.</i>	Reset totalizer
<i>ACK.TOT.</i>	New value for totalizer



## 6.5 Totalizer Function

<code>TOTAL</code>	Menu Totalizer
<code>CUT.OFF</code>	Select value for low threshold cut-off
<code>-1999.99</code>	Setting range -199999 ... +999999 and decimal point
<code>FACTOR</code>	Select value for multiplication factor
<code>1.000000</code>	Setting range 0.00001 ... 9.99999
<code>SCALE</code>	Select scale factor
<code>x 1</code>	Scale factor x 1, x 0,1, x 0,01, x 0,001 or x 0,0001
<code>DP.TOT.</code>	Select decimal point for totalizer (visual function only)
<code>0</code>	Format 0, 0.0, 0.00, 0.000, 0.0000 or 0.00000

Using ACK.TOT the current (instantaneous) measured value (throughput rate) will be added into the totalizer memory. To convert the throughput rate into other units FACTOR and SCALE are available. Negative measured values are also taken into consideration. A decimal point that is programmed with a current measured value is not taken into consideration. A dummy decimal point (optical indication only) can be programmed into the totalizer as required.

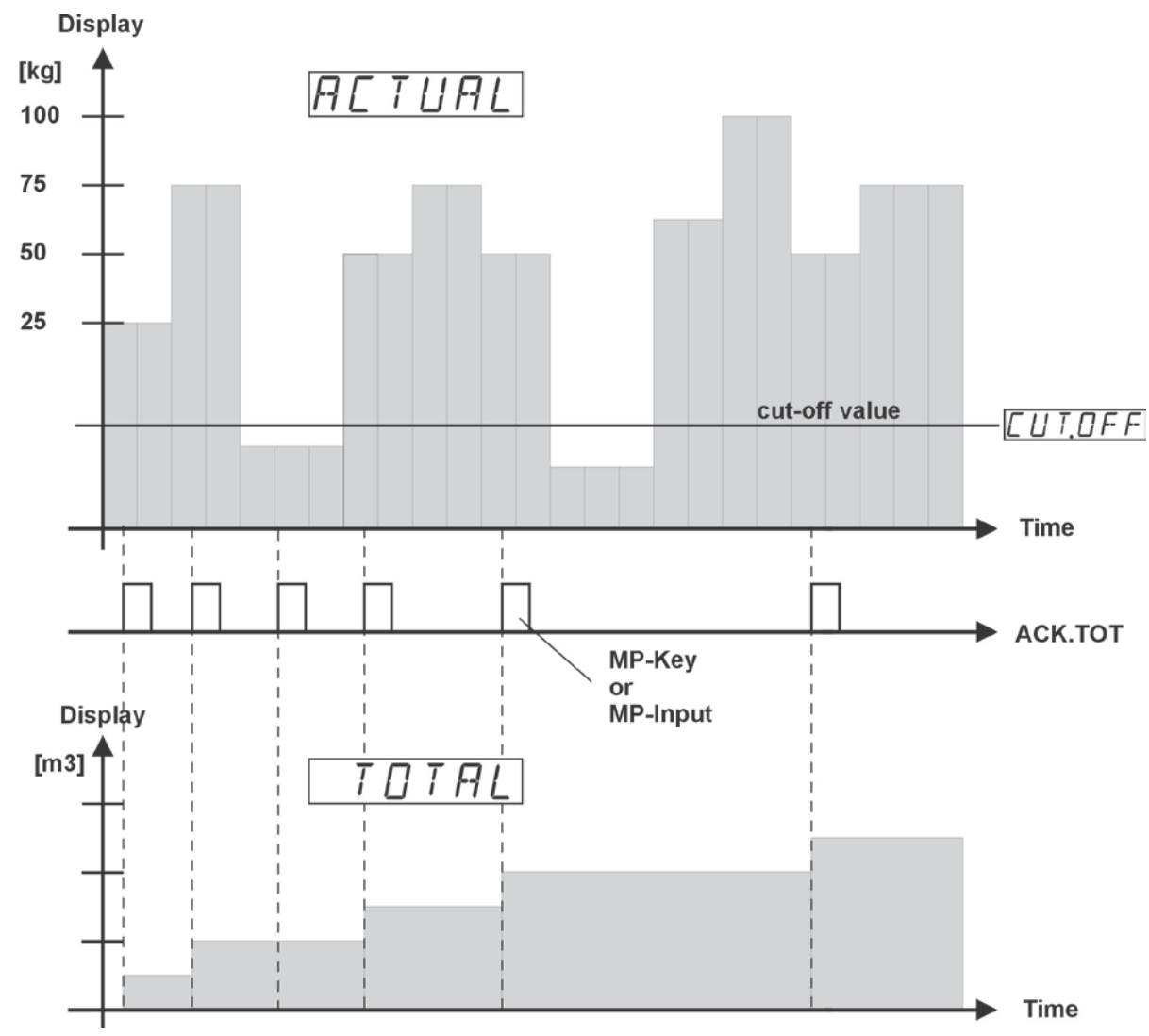

## 6.6 Limit Value (Alarm) Monitoring

<b>ALARM 1</b>	<b>Menu Alarm Output 1</b>
<b>AL.OUT 1</b>	<b>Select operating mode</b>
OFF	OFF
AUTO	Automatic operation
LATCH	Memory latch operation - not with band limitation
<b>ALLOC. 1</b>	<b>Select source value for Alarm output 1</b>
ACTUAL	Current measured value
TOTAL	Totalizer
<b>MD.OUT 1</b>	<b>Select Output triggering</b>
INCR	With incrementing measuring signal
DECR	With decrementing measuring signal
BAND	Band limitation
<b>FM.OUT 1</b>	<b>Select Alarm status</b>
---F--	With alarm: output active
--7---	With alarm: output inactive
<b>ON.HYS. 1</b>	<b>Select ON-hysteresis</b>
0.000	Setting range 0 ... +9999 and decimal point
<b>OF.HYS. 1</b>	<b>Select OFF-hysteresis (only with auto operation)</b>
0.000	Setting range 0 ... +9999 and decimal point
<b>ON.DLY. 1</b>	<b>Select ON-delay</b>
0.0	Setting range 0.0 ... 99.9 [sec]
<b>OF.DLY. 1</b>	<b>Select OFF-delay (only with auto operation)</b>
0.0	Input range 0.0 ... 99.9 [sec]
<b>ALARM 2</b>	<b>Menu Alarm Output 2</b>
<b>AL.OUT 2</b>	<b>Select operating mode</b>
OFF	OFF
AUTO	Automatic operation
LATCH	Memory latch operation

<i>ALLO.C.2</i>	Select source value for Alarm output 2
<i>ACTUAL</i>	Current measured value
<i>TOTAL</i>	Totalizer
<i>M.D.OUT.2</i>	Select Output triggering
<i>INCR</i>	With incrementing measuring signal
<i>DECR</i>	With decrementing measuring signal
<i>BAND</i>	Band limitation
<i>FM.OUT.2</i>	Select Alarm status
<i>---F---</i>	With alarm: output active
<i>---7---</i>	With alarm: output inactive
<i>ON.HY.5.2</i>	Select ON-hysteresis
<i>0.000</i>	Setting range 0 ... +9999 and decimal point
<i>OF.HY.5.2</i>	Select OFF-hysteresis (only with auto operation)
<i>0.000</i>	Setting range 0 ... +9999 and decimal point
<i>ON.DLY.2</i>	Select ON-delay
<i>0.0</i>	Setting range 0.0 ... 99.9 [sec]
<i>OF.DLY.2</i>	Select OFF-delay (only with auto operation)
<i>0.0</i>	Input range 0.0 ... 99.9 [sec]

### 6.6.1 Explanatory notes

<i>INCR</i>	ON switching point = limit value + ON hysteresis OFF switching point = limit value – OFF hysteresis
<i>DECR</i>	ON switching point = limit value – ON hysteresis OFF switching point = limit value + OFF hysteresis
<i>BAND</i>	An alarm is triggered, if the measured value falls outside a defined range (Band). Upper switching point = limit value + ON hysteresis Lower switching point = limit value – OFF hysteresis
<i>---F---</i>	An alarm causes the output to become active (Relay energized, LED ON)
<i>---7---</i>	An alarm causes the output to become inactive (Relay not energized, LED OFF)
<i>PW.DELY.</i>	<i>LATCH</i> In memory latch operation the status of the outputs is stored in the event of a Power OFF condition and then immediately restored at the next Power ON.
<i>PW.DELY.</i>	<i>AUTO</i> In auto operation the status of the outputs is not saved in the event of a Power OFF condition. At the next Power ON the limit values are not processed until after the expiration of the start delay (PW.DELY)

### 6.6.2 Control with incrementing measuring signal

**INCR**

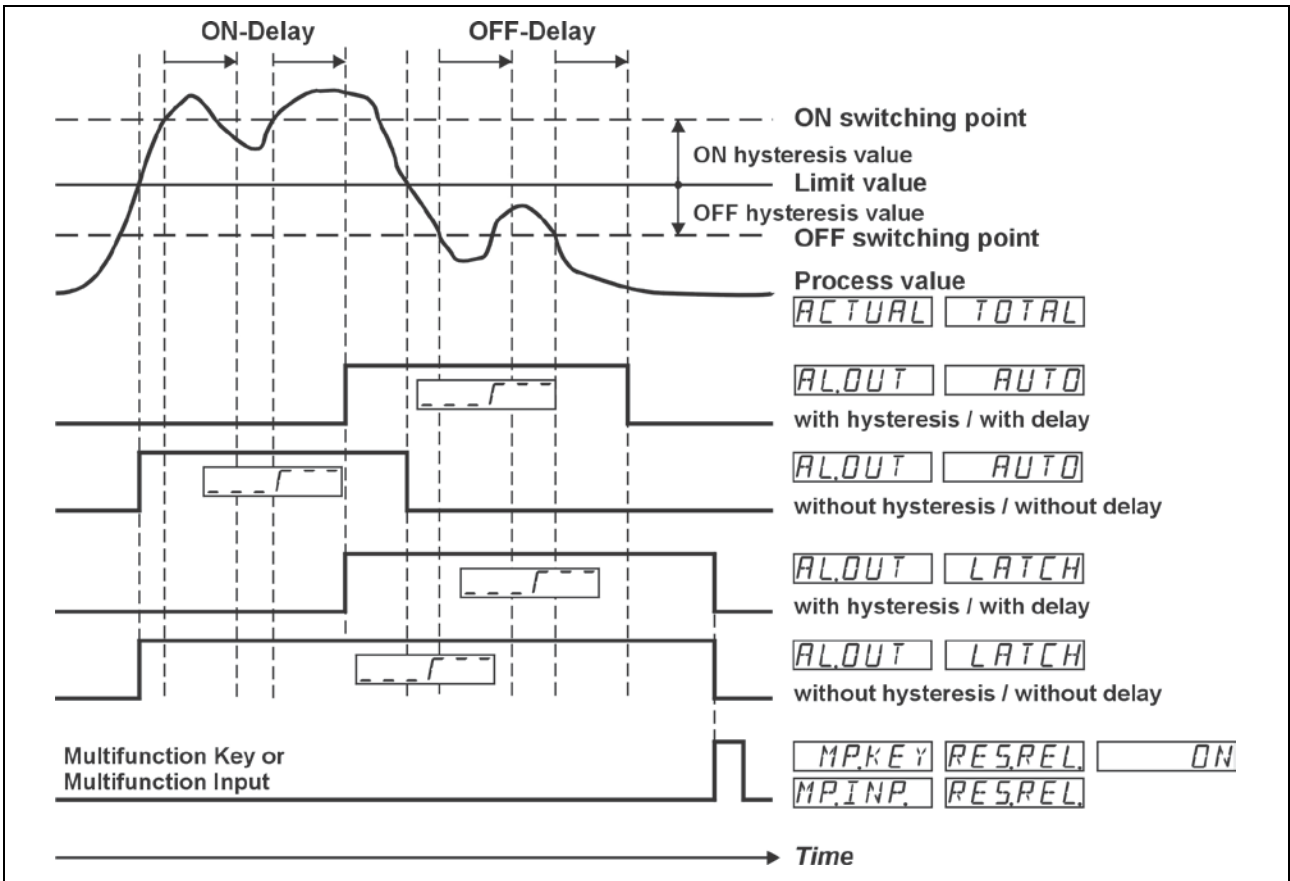

### 6.6.3 Control with decrementing measuring signal

**DECR**

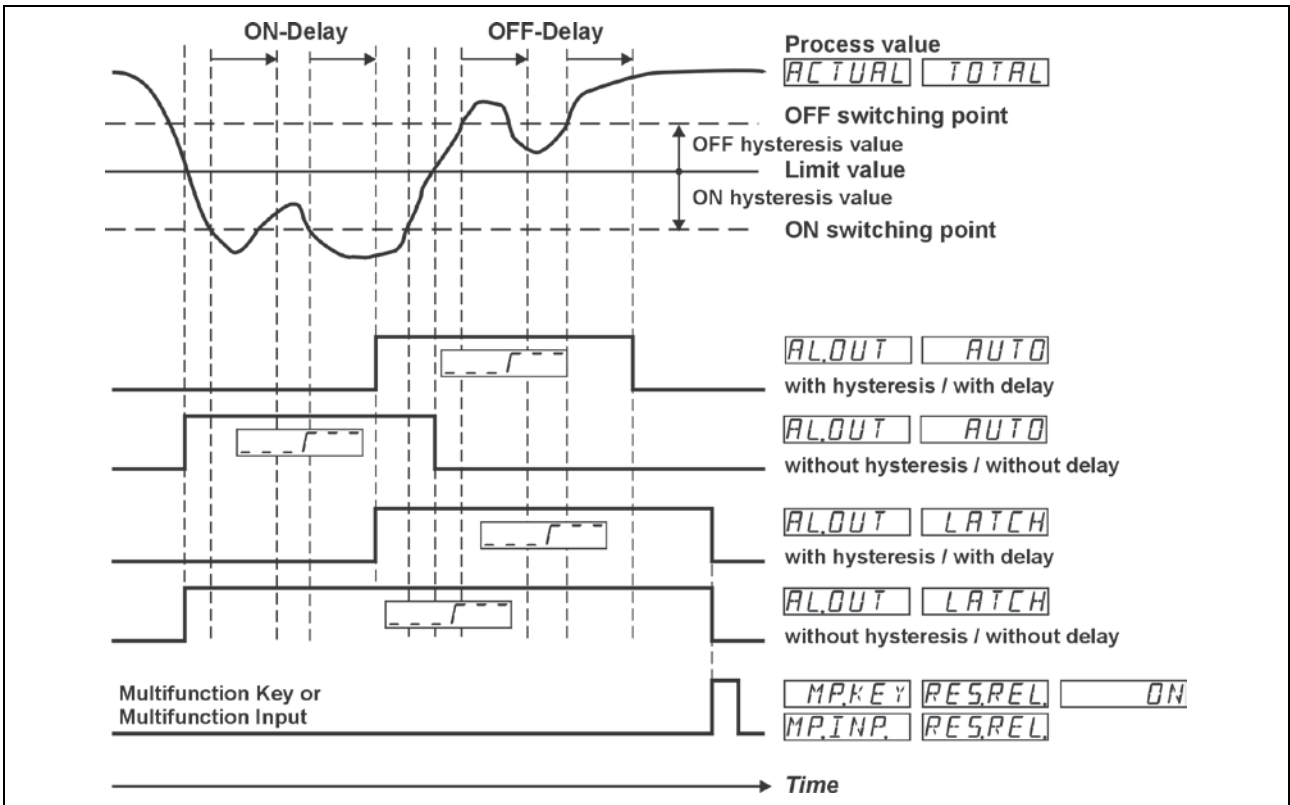

### 6.6.4 Control with Band Limitation

BAND

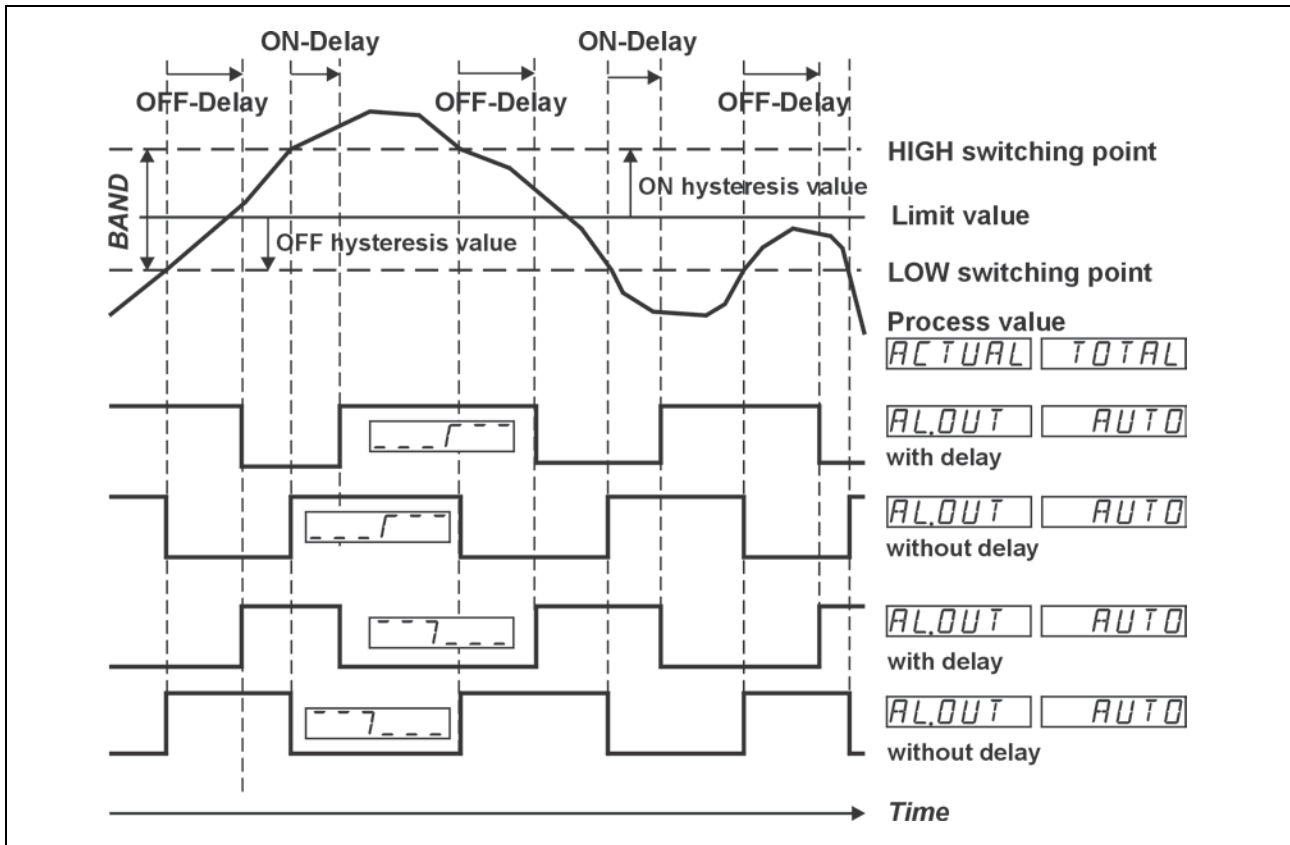

### 6.7 Monitoring of the Measuring Circuit

Measuring Range	Lower Display Range Limit	Upper Display Range Limit	Lower Meas. Range Limit	Upper Meas. Range Limit	Probe or wire short circuit, Probe or wire break 1) 2)
3,3 mV/V	DISPLO	DISPHI	LOLIM	HILIM	
3,0 mV/V	■	■	■	■	■
2,0 mV/V	■	■	■	■	■
1,5 mV/V	■	■	■	■	■
1,0 mV/V	■	■	■	■	■
Indication	-1.9.9.9.9. blinking	9.9.9.9.9. blinking	UNDEF. blinking	OVERFL. blinking	SENSOR blinking

(■ = is detected)

1) Wire short circuit between **Signal input +** and **Signal input -** is not detected.

2) Wire break with **Sensor supply +** or **Sensor supply -** is not detected.

## 7. Technical Specifications

<b>General Data</b>	
Display:	6-digit, 14 segment LED
Digit height:	14 mm
Data retention:	> 10 years, EEPROM
Operation:	5 keys
<b>Measuring signal inputs</b>	
Sampling rate:	10 readings/sec
Input resistance:	1 M $\Omega$
Max. measuring signal range:	approx. $\pm 35$ mV
Max. voltage	$\pm 10$ V.
<b>Signal input at 3.3 mV/V, 3.0 mV/V and 2.0 mV/V</b>	
Resolution:	$\pm 15$ bits
Measuring accuracy @ 23°C:	typ. 0,05 % of range, max. $\leq 0,05$ % of range
Temperature drift:	< 100 ppm/K
<b>Signal input at 1.5 mV/V and 1.0 mV/V</b>	
Resolution:	$\pm 14$ bits
Measuring accuracy @ 23°C:	typ. 0,1 % of range, max. $\leq 0,2$ % of range
Temperature drift:	< 100 ppm/K
<b>Control inputs MPI 1 / MPI 2</b>	
Quantity:	2 optocoupler inputs with programmable function
Switching levels:	Low: < 2 V, High: > 4 V (max. 30 V)
Pulse length:	> 100 ms
<b>Alarm outputs</b>	
Relays:	dry change-over contacts
Switching voltage:	max. 250 V AC / 125 V DC, min. 5 V AC / V DC
Switching current:	max. 5 AAC / ADC, min. 10 mA
Switching capacity:	max. 1250 VA / 150 W
Mechanical service life (switching cycles)	$1 \times 10^7$
No. of switching cycles at 5 A / 250 V AC	$5 \times 10^4$
No. of switching cycles at 5 A / 30 V DC	$5 \times 10^4$

<b>Supply voltage</b>	
AC supply:	90 ... 260 V AC / max. 9 VA, 50 / 60 Hz
External fuse protection:	T 0,1 A
DC supply (in-built galvanic isolation)	10 ... 30 V DC / max. 3,5 W with reverse polarity protection
External fuse protection:	T 0,4 A
Mains hum suppression	50 Hz or 60 Hz, programmable
<b>Sensor supply voltage</b>	
AC supply:	24 V DC $\pm$ 15 %, 30 mA and 10 V DC $\pm$ 1 %, 30 mA
DC supply:	10 V DC $\pm$ 1 %, 30 mA only
<b>Climatic conditions</b>	
Operating temperature:	-20°C ... +65°C (-4°F ... +149°F)
Storage temperature:	-25°C ... +75°C (-13°F ... +167°F)
Relative humidity	R.H. 93 % at +40°C (104°F), non-condensing
Altitude:	up to 2000 m (6,562 ft)
<b>EMC</b>	
Noise immunity:	EN 61000-6-2 (with shielded signal and control cables)
Noise emission:	EN 55011 Class B
<b>Device safety</b>	
Designed to:	EN61010 part 1
Protection class:	Protection class 2
Application area:	Pollution level 2
<b>Mechanical data</b>	
Housing:	Panel mount housing to DIN 43 700, RAL 7021
Dimensions:	96 x 48 x 102 mm (3.78 x 1.89 x 4.02")
Panel cut out:	92 <sup>+0,8</sup> x 45 <sup>+0,6</sup> mm (3.62+0.03" x 1.77+0.23")
Installation depth:	ca. 92 mm (3.62") including terminals
Weight:	ca. 180 g
Protection:	IP 65 (front)
Housing material:	Polycarbonate UL94 V-2
Vibration resistance EN60068-2-6:	10 - 55 Hz / 1 mm / XYZ, 30 min in each direction
Shock resistance: EN60068-2-27 EN60068-2-29	100G / XYZ, 3 times in each direction 10G / 6 ms / XYZ, 2000 times in each direction
Cleaning:	The front of the unit should only be cleaned using a damp (water!) cloth.
<b>Connections</b>	
Supply voltage and outputs:	Plug-in screw terminal 8-pos., pitch 5.00 mm, Core cross section max. 2,5 mm <sup>2</sup>
Signal and control inputs:	Plug-in screw terminal 9-pos. pitch 3,50 mm, Core cross section max. 1,5 mm <sup>2</sup>

## 8. Dimensional Drawings

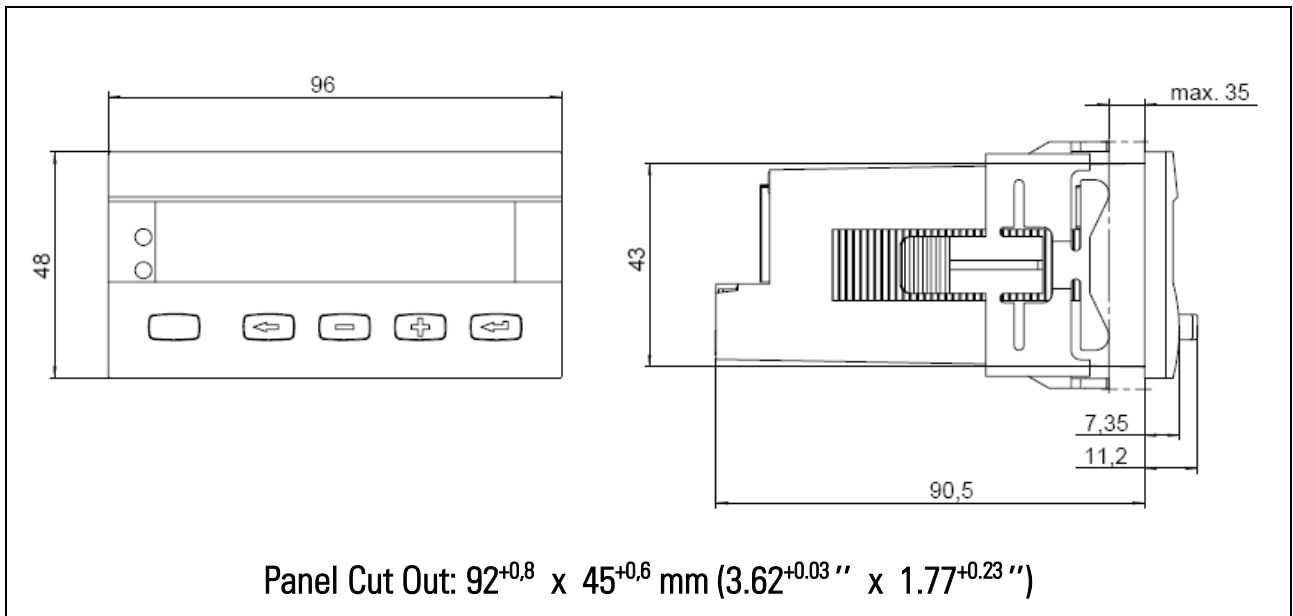



# 9. Help Texts

PROG.	NO	NO PROGRAMMING
PROG.	YES	START PROGRAMMING
HLP.TXT.		MAIN MENU SELECT HELPTTEXT
HLP.TXT.	ON	HELPTTEXTS ON
HLP.TXT	OFF	HELPTTEXTS OFF
SL.LANG.	DE	SPRACHE DEUTSCH
SL.LANG.	EN	LANGUAGE ENGLISH
INPUT.		MAIN MENU SIGNAL INPUT
RANGE	3.3MV/V	INPUT RANGE 3.3MV/V
RANGE	3.0MV/V	INPUT RANGE 3.0MV/V
RANGE	2.0MV/V	INPUT RANGE 2.0MV/V
RANGE	1.5MV/V	INPUT RANGE 1.5MV/V
RANGE	1.0MV/V	INPUT RANGE 1.0MV/V
LO.LIM.		LOWER INPUT RANGE LIMIT
HI.LIM.		UPPER INPUT RANGE LIMIT
DP.	0	NO DECIMAL POINT
DP.	0.0	DECIMAL POINT 0.0
DP.	0.00	DECIMAL POINT 0.00
DP.	0.000	DECIMAL POINT 0.000
DP.	0.0000	DECIMAL POINT 0.0000
DP.	0.00000	DECIMAL POINT 0.00000
INP.LO.		INPUT START VALUE
DISP.LO.		DISPLAY START VALUE
INP.HI.		INPUT END VALUE
DISP.HI.		DISPLAY END VALUE
FILTER		INPUT FILTER
PW.DELY.		POWER-ON DELAY FOR OUTPUTS [SEC]
PW.FREQ.	50HZ	POWER LINE FREQUENCY 50HZ
PW.FREQ.	60HZ	POWER LINE FREQUENCY 60HZ
LINEAR.		MAIN MENU LINEARIZATION
LINEAR.	NO	LINEARIZATION OFF
LINEAR.	YES	LINEARIZATION ON
NUM.PNT.		NUMBER OF LINEARIZATION POINTS
INP.01		INPUT VALUE NO.1
DISP.01		DISPLAY VALUE NO.1
to		
INP.10		INPUT VALUE NO.10
DISP.10		DISPLAY VALUE NO.10
MP.KEY		MAIN MENU MP-BUTTON
TARA	OFF	FUNCTION TARA OFF
TARA	ON	FUNCTION TARA ON
RES.MIN.	OFF	FUNCTION RESET MIN VALUE OFF
RES.MIN.	ON	FUNCTION RESET MIN VALUE ON
RES.MAX.	OFF	FUNCTION RESET MAX VALUE OFF
RES.MAX.	ON	FUNCTION RESET MAX VALUE ON
RES.REL.	OFF	FUNCTION RESET OUTPUT-LATCH OFF
RES.REL.	ON	FUNCTION RESET OUTPUT-LATCH ON
RES.TOT.	OFF	FUNCTION RESET TOTALIZER VALUE OFF
RES.TOT.	ON	FUNCTION RESET TOTALIZER VALUE ON

ACK.TOT.	OFF	FUNCTION ADD MEASURED VALUE TO TOTALIZER OFF
ACK.TOT.	ON	FUNCTION ADD MEASURED VALUE TO TOTALIZER ON
MP.INP.		MAIN MENU MP-INPUTS
MP.INP.x	NO.FUNC.	NO FUNCTION
MP.INP.x	RES.MIN.	FUNCTION RESET MIN VALUE
MP.INP.x	RES.MAX.	FUNCTION RESET MAX VALUE
MP.INP.x	R.PEAKS	FUNCTION RESET MIN/MAX VALUES
MP.INP.x	RES.REL.	FUNCTION RESET OUTPUT-LATCH
MP.INP.x	DISP.HD.	FUNCTION DISPLAY HOLD
MP.INP.x	LOC.AL.R.	FUNCTION LOCK EDITING ALARM VALUES
MP.INP.x	LOC.PRG.	FUNCTION LOCK PROGRAMMING
MP.INP.x	LOC.KEY	FUNCTION LOCK KEYS
MP.INP.x	TARA	FUNCTION TARA
MP.INP.x	R.TARA	FUNCTION RESET TARA VALUE
MP.INP.x	RES.TOT	FUNCTION RESET TOTALIZER VALUE
MP.INP.x	ACK.TOT	FUNCTION ADD MEASURED VALUE TO TOTALIZER
TOTAL		MAIN MENU TOTALIZER
CUT.OFF		CUT OFF VALUE
FACTOR		MULTIPLICATION FACTOR TOTALIZER
SCALE	x1	SCALING FACTOR TOTALIZER X1
SCALE	x0.1	SCALING FACTOR TOTALIZER X0.1
SCALE	x0.01	SCALING FACTOR TOTALIZER X0.01
SCALE	x0.001	SCALING FACTOR TOTALIZER X0.001
SCALE	x0.0001	SCALING FACTOR TOTALIZER X0.0001
DP.TOT.	0	NO DECIMAL POINT
DP.TOT.	0.0	DECIMAL POINT TOTALIZER 0.0
DP.TOT.	0.00	DECIMAL POINT TOTALIZER 0.00
DP.TOT.	0.000	DECIMAL POINT TOTALIZER 0.000
DP.TOT.	0.0000	DECIMAL POINT TOTALIZER 0.0000
DP.TOT	0.00000	DECIMAL POINT TOTALIZER 0.00000
ALARMx		MAIN MENU ALARM x
AL.OUTx	OFF	ALARM x OFF
AL.OUTx	AUTO	AUTOMATIC MODE OF ALARM OUTPUT x
AL.OUTx	LATCH	LATCH MODE OF ALARM OUTPUT x
ALLOC.x	ACTUAL	ACTUAL VALUE TO ALARM
ALLOC.x	TOTAL	TOTALIZER TO ALARM
MD.OUTx	INCR	ALARM x ACTIVE AT INCREASING INPUT SIGNAL
MD.OUTx	DECR	ALARM x ACTIVE AT DECREASING INPUT SIGNAL
MD.OUTx	BAND	ALARM x BAND LIMITATION
FM.OUTx		OUTPUT ACTIVE AT ALARM
FM.OUTx		OUTPUT INACTIVE AT ALARM
ON.HYS.x		SWITCH ON HYSTERESIS ALARM x
OF.HYS.x		SWITCH OFF HYSTERESIS ALARM x
ON.DLY.x		ON DELAY ALARM x [SEC]
OF.DLY.x		OFF DELAY ALARM x [SEC]
END.PRG.	NO	REPEAT PROGRAMMING
END.PRG.	YES	EXIT PROGRAMMING AND STORE DATA
-1.9.9.9.9		DISPLAYRANGE UNDERFLOW
9.9.9.9.9.		DISPLAYRANGE OVERFLOW
OVERFL.		OVERFLOW UPPER INPUT RANGE LIMIT
UNDERF.		UNDERFLOW LOWER INPUT RANGE LIMIT
SENSOR		SENSOR ERROR