

MICROPROCESSOR MOTOR SPEED CONTROLLERS

MODEL 1207B



CURTIS



DESCRIPTION

Curtis PMC 1207B series motor speed controllers are the direct replacements for the earlier 1207A models. They feature a microprocessor based logic section combined with a proven MOSFET power section. The 1207B series controllers are efficient, cost effective and easy to install.

APPLICATION

The Curtis PMC 1207B controllers are ideally suited for small electric vehicle applications, such as walkie fork/pallet trucks, mini personnel carriers, sweepers, and other small series or compound motor applications.

FEATURES

- Advanced high frequency power section utilizing custom power MOSFETs provides high efficiency, silent operation and reduced motor and battery losses.
- Thermal protection and compensation circuitry provide under temperature cutback, constant current limit over the operating range and linear rollback in over temperature. No sudden loss of power under any thermal conditions.
- Power connections made by solid copper busses with polarized Molex connector for control signals.
- Compact size.
- Over voltage and under voltage protection.
- Fully compatible with Curtis PC software tools and hand held programmers for full parametric adjustment, tuning, test and diagnostics.
- Complete diagnostics of the controller can also be accomplished with the built-in status LED.
- Meets or exceeds EEC fault detection requirements with circuitry and software to detect faults in the throttle circuit, MOSFET drive circuits, MOSFET transistors, contactor drivers and contactors.
- Input sequencing options include neutral start (HPD) and static return to off (SRO).
- True arcless contactor switching with microprocessor controlled contactor sequencing.
- Throttle position variable or fixed plugging current options.
- Neutral braking option provides for automatic plug braking in neutral.
- MultiMode™ option for programmable two mode (current limit, speed, acceleration) operation.
- Emergency reverse function (belly button) provides full function with a single input. Additional output provides for an emergency reverse circuit continuity check.
- Anti-rollback (ramp start) function gives full power for starting on ramps.
- Simple contactor and switch wiring. Coil drivers are monitored for short and open circuit for fail-safe operation.
- Flexible throttle circuitry accepts a variety of throttle types including: 5k-0, 0-5k, 0-5v, and three wire potentiometer.
- Programmable output for use as either a main contactor driver or a shunt field driver.

MODEL 1207B

MODEL CHART

Curtis PMC Models	Voltage (Volts)	1 Minute Rating (Amps)	5 Minute Rating (Amps)	1 Hour Rating (Amps)	Typ. Voltage Drop @ 100A (Volts)	Undervoltage Cutback (Volts)	Ambient Temp. Range (C°)
1207B-41XX	24	250	150	100	0.35	16	-25 to 50
1207B-51XX	24	300	170	110	0.30	16	-25 to 50

DIMENSIONS mm

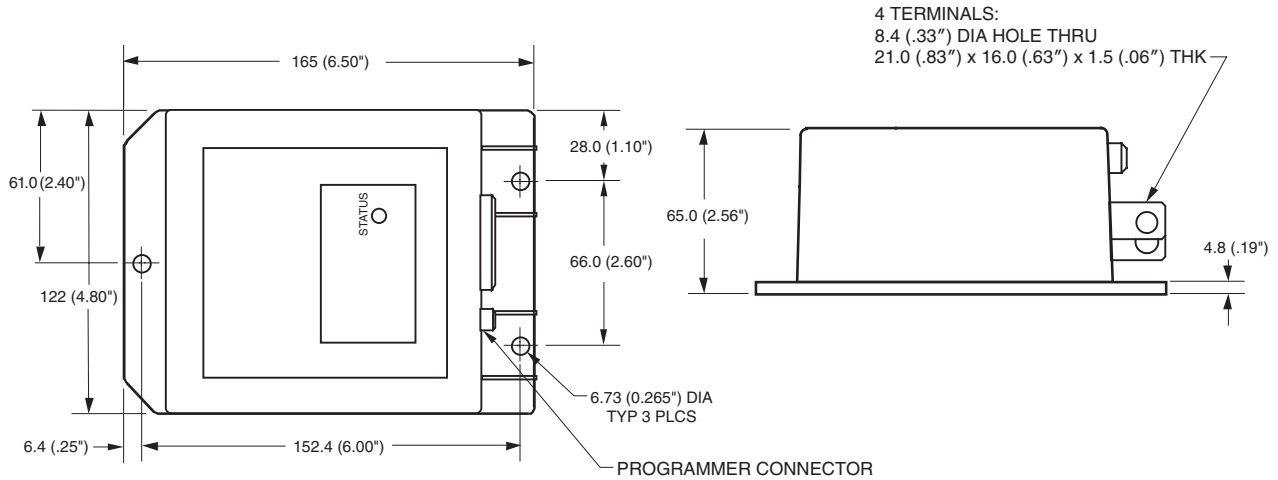

TYPICAL WIRING

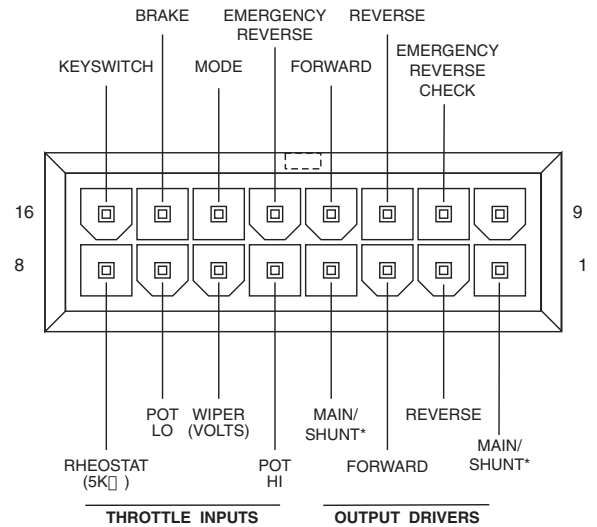
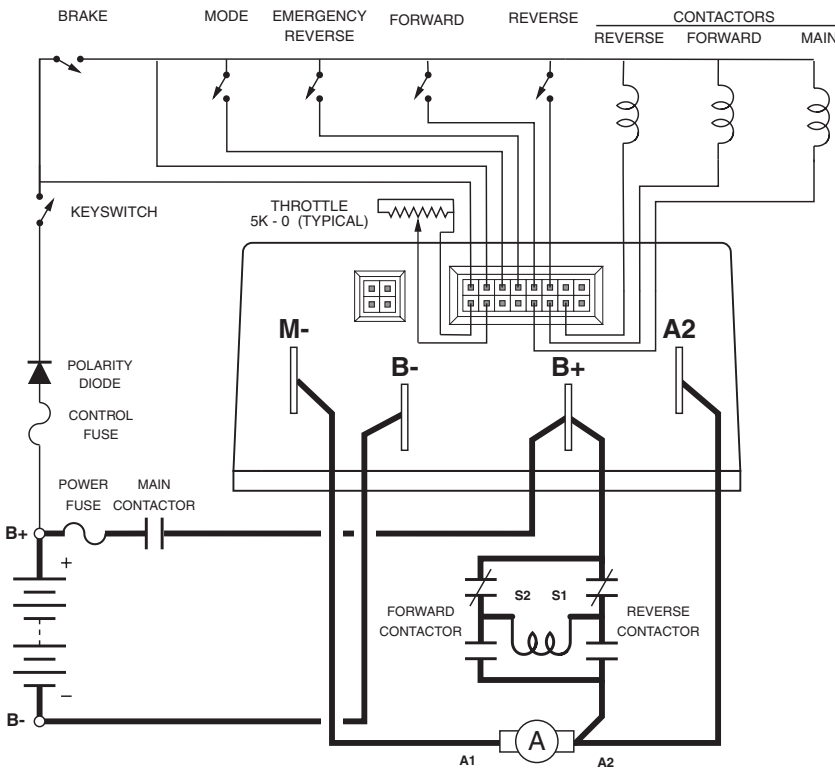

WARRANTY Two year limited warranty from time of delivery.



is a trademark of Curtis Instruments, Inc.

Specifications subject to change without notice

©2012 Curtis Instruments, Inc.

50210 REV A 6/12

The Curtis Difference
You feel it when you drive it

